

Operating Instructions

LAUDA Ultra-Thermostats
UB 20(-D), UB 25, UB 30, UB 40, UB 50
UB 20 F, UB 20 J, UB 30 J, UB 40 J, UB 65 J
UB 20 JL, UB 30 JL, UB 40JL

from series Z 01
software version 2.16
01/01
YATE0013

LAUDA DR. R. WOBSE
R GMBH & CO. KG
P.O. Box 1251
97912 Lauda-Königshofen
Tel: (+49) (0) 9343/ 503-0
Fax: (+49) (0) 9343/ 503-222
E-mail info @ lauda.de
Internet <http://www.lauda.de>

1	BRIEF OPERATING INSTRUCTIONS	6
1.1	Fitting the tubing to the pump connections:.....	6
1.2	Operating safety	7
1.3	WARNING:.....	7
2	TECHNICAL DATA TO DIN 58966	8
2.1	Thermostat.....	8
2.2	Controller R 400-P	11
3	GENERAL CONSTRUCTION AND TECHNICAL DESCRIPTION	15
3.1	Operating principle and type characteristics	15
3.2	Materials.....	16
3.3	Cooling coil.....	16
3.4	Pumps	16
3.5	Temperature control and electronics.....	17
3.6	Mains supply output 34 H.....	18
3.7	Controlled cooling.....	18
4	SAFETY DEVICES AND WARNING NOTES	18
4.1	Safety functions	18
4.2	Why can a thermostat be dangerous?	19
4.3	Important notes	19
4.4	Warning notes	20
4.4.1	Temperatures.....	20
4.4.2	Mains connection	20
4.4.3	Mains cable and connecting cables	20
4.4.4	Fume extraction	20
4.4.5	Cooling water, steam production.....	20
5	BATH LIQUIDS AND HOSE CONNECTIONS	21
5.1	Bath liquids.....	21
5.2	Hose connections	22
5.2.1	Perbunan tubings	22
5.2.2	Silicone tubings	23
5.2.3	Metal hoses.....	23
6	UNPACKING, ASSEMBLY AND SETTING UP	24
6.1	Unpacking	24
6.2	Setting up, operation as bath thermostat.....	24
7	CONNECTION OF EXTERNAL SYSTEMS	25
7.1	Circulation pumps.....	25

7.2	Closed external circuits.....	25
7.3	Open systems (baths).....	26
8	COOLING THE THERMOSTATS.....	27
8.1	Mains water cooling.....	27
8.2	Through-flow chillers DLK 10, DLK 25 and DLK 45.....	27
9	STARTING UP.....	28
9.1	Filling.....	28
9.2	Connection to supply.....	28
9.3	Basic functions.....	28
9.3.1	Supply switch-on.....	28
9.3.2	Standard display.....	29
9.3.3	Basic action on inputs and outputs.....	30
9.3.4	Overtemperature switch-off point.....	30
9.3.5	Low temperature switch-off point.....	31
9.3.6	Setpoint input.....	32
9.4	Parameter level PAR.....	32
9.4.1	Auto-adaptation.....	32
9.4.2	Output limitation.....	33
9.4.3	Display resolution L1.....	34
9.4.4	Contact input Fault 14 N.....	34
9.4.5	Baud rate RS 232.....	35
9.4.6	Menu language.....	35
9.4.7	Calibrating the analogue output channels.....	35
9.4.8	Operation with through-flow chiller DLK 45 with proportional cooling.....	36
9.5	Calibration of the temperature measurement circuits.....	36
9.6	Control parameters.....	38
9.6.1	Indication and input of the control parameters.....	38
9.6.2	Recommendations for the control parameters.....	38
9.6.3	Bath temperature limitation.....	39
9.6.4	Correction limitation.....	39
9.7	External control.....	40
9.7.1	External measurement inputs and external controller.....	40
9.7.2	Start of external control.....	41
9.7.3	Notes.....	41
9.8	Working with controlled cooling.....	42
9.9	Operation with programmer.....	44
9.9.1	Programme input.....	44
9.9.2	Example of a programme.....	46
9.9.3	Programme test.....	47
9.9.4	Changing the programme data.....	47
9.9.5	Programme start, interruption and abort.....	47
9.10	Connection for analogue signals socket 52 S.....	48
9.11	Analogue inputs.....	49
9.12	Analogue outputs.....	52
9.12.1	Temperature signal channel 1.....	52
9.12.2	Temperature signal channel 2.....	54

9.13 Safety function	54
9.13.1 Low-level cut-out	54
9.13.2 Adjustable overtemperature limiter	54
9.13.3 Connection potential-free contact "Combined fault" 12 N (Alarm off)	56
9.14 Serial interface RS 232 C	56
9.14.1 Data of the RS 232 C interface	56
9.14.2 General principles	57
9.14.3 Output commands.....	57
9.14.4 Requesting data from the thermostat.....	59
9.14.5 Error messages on the computer	61
9.15 Timing clock function	61
9.15.1 Setting and indication of date and time	61
9.15.2 Timing clock function	62
9.15.3 Activating the timing clock function	62
10 MAINTENANCE	63
10.1 Safety notes in case of repairs	63
10.2 Repair and re-initialisation	63
10.3 Cleaning	64
10.4 Spares ordering.....	64
11 ACCESSORIES	65

1 Brief Operating Instructions

Even if you find these brief instructions initially sufficient please read the following sections, especially Section 4: "Safety devices and warning notes".

For safe operation of the equipment it is essential that the information in these Operating Instructions is observed.

Check the thermostat and the accessories during unpacking for any transport damage and if necessary inform the carrier or the postal authority.

Assemble the unit according to Section 6 and add extra items as appropriate.

1.1 ***Fitting the tubing to the pump connections:***

Without external system: for improved circulation within the bath fit the tubing nipples and link them together with e.g. Perbunan tubing (up to 120°C) or better a metal tubing; open the pump adjustment lever.

With external system: connect the tubings to the external system.

Protect the tubing with hose clips against slipping off.



When working near the ambient temperature connect up the external cooling according to Section 8.

Use only softened water or LAUDA bath liquids (Section 5). Fill up the bath to a level about 2 cm below the cover plate.

Check the supply voltage against the details on the label.
Insert the mains plug.

Switch on the supply switch (green lamp lights up).

The display shows the software version and the type of unit (R 400 P), followed by the standard display.

Select the required indications using the keys  and  in the SHIFT mode.

It is useful to show the setpoint (Ts) in display line 2 (L2) (see Items 9.3.1 - 9.3.3).

Set the overtemperature switch-off point (To) slightly above the operating temperature.

If there is an error message, press the key  and perhaps increase To.

Important: To must be at least 25 K below the fire point of the bath liquid used (see Item 9.3.4).

When connecting up an external system, check that filling this system does not cause the level inside the thermostat to fall more than is permitted.

When the thermostating liquid has reached the setpoint the symbol  starts to flash on the right in line 1 (L1) of the display.

After the unit has stabilised the bath temperature (T_i) corresponds to the setpoint (T_s).

1.2 Operating safety

The thermostat must be operated with non-flammable bath liquids only, or with flammable bath liquids up to 25°C below their fire point, otherwise there is a possibility that a flammable atmosphere may form (see Item 4.2).

1.3 WARNING:

Parts of the bath cover may reach temperatures above 70°C when working at higher temperatures. The outflow and return pipes of the pumps reach the operating temperature. Touching them is dangerous because of very high or low temperatures.

2 Technical data to DIN 58966

2.1 Thermostat

		UB 20 UB 20-D	UB 25	UB 50	UB 30	UB 40
Operating temperature range (with external cooling and cover plates)	(°C)	-60...300	-30...300	-30...300	-30...300	-30...300
Working temperature range						
Simplex	(°C)	45...300	40...200	35...200	40...300	35...300
Duplex (-D)	(°C)	50...300	---	---	---	---
with water cooling	(°C)	20...300	20...200	20...200	20...300	20...300
Temperature sensor		Pt 100 Class B to DIN IEC 751				
Temperature variation at 70°C in the bath	(°C)	± 0.01*)	± 0.02*)	± 0.02*)	± 0.01*)	± 0.01*)
Heater power (max.)	(kW)	3	3	3	3	3
Safety system		2nd resistance thermometer and level sensor				
<u>Simplex pump</u>						
Pump output against zero head	(l/min)	22	18	15	15	15
Pump pressure (max.)	(bar)	0.5	0.4	0.3	0.3	0.3
<u>Duplex pumps (-D)</u>						
pump output						
Pressure/suction	(l/min)	20/15	---	---	---	---
Pump pressure (max.) (Pressure/suction)	(bar)	0.5/0.33	---	---	---	---
Pump connections		M 16 x 1; nipples 13 Ø				
Filling volume	(l)	13...17.5	19...26	33...46	17.5...30	27...40
Bath opening (W x D)	(mm)	250x265	250x455	250x905	250x265	250x265
Bath depth	(mm)	195	195	195	320	450
Usable liquid depth	(mm)	175	175	175	300	430
Height to top of bath	(mm)	265	265	265	390	520
Bench area (W x D) x Height (only thermostat)	(mm)	(300x450)x465	(640x300)x465	(1090x300)x465	(300x450)x590	(300x450)x720
Weight (with R 400-P)	(kg)	27	31	41	33	39
Supply		230 V; 50 Hz / 230 V; 60 Hz				
	(kW)	3.2	3.2	3.2	3.2	3.2
		Protection Class 1 to VDE 0106				

Units are conform to EU Guideline 89/336/EWG (EMC) and 73/23/EWG (low-voltage) and carry the CE mark (230 V; 50 Hz).

Cat. No. compl. with R 400-P

230 V; 50 Hz

Simplex Pump

LTB 130

LTB 132

LTB 133

LTB 134

LTB 135

Duplex Pump

LTB 131

230 V; 60 Hz

Simplex Pump

LTB 230

LTB 232

LTB 233

LTB 234

LTB 235

Duplex Pump

LTB 231

*) see Item 4.3

Technical changes reserved.

LAUDA Ultra-Thermostats
 UB 20(-D), UB 25, UB 50,
 UB 20 F, UB 20 J, UB 30 J, UB 40 J, UB 65 J
 UB 20 JL, UB 30 JL, UB 40 JL

Technical data to DIN 58966

		UB 20 F	UB 20 J	UB 30 J	UB 40 J	UB 65 J
Operating temperature range (with external cooling)	(°C)	-30...200	-30...300	-30...300	-30...300	-30...300
Working temperature range Simplex	(°C)	35...200	45...300	45...300	45...300	40...300
with water cooling	(°C)	20...200	20...300	20...300	20...300	20...300
Temperature sensor		Pt 100 Class B to DIN IEC 751				
Temperature variation at 70°C in the bath	(°C)	± 0.005*			± 0.005... ± 0.01*	
Heater power (max.)	(kW)	1,2	3	3	3	3
Safety system		2nd resistance thermometer and level sensor				
<u>Simplex pump</u>						
Pump output against zero head (outside the bath)	(l/min)	12	15	15	15	15
Pump pressure (max.)	(bar)	0.2	0.3	0.3	0.3	0.3
Pump connections		M 16 x 1; nipples 13 Ø				
Filling volume	(l)	15...18	15...18	22.5...30.5	32...40.5	48...54
Bath opening	(mm)			Ø 195		Ø 215
Bath depth	(mm)	195	195	320	450	690
Usable liquid depth	(mm)	175	175	300	430	650
Height to top of bath	(mm)	265	265	390	520	755
Bench area (W x D) x Height (only thermostat)	(mm)	(300x450)x465	(300x450)x465	(300x450)x590	(300x450)x720	(320x485)x955
Weight (with R 400-P)	(kg)	27	27	33	39	60
Supply		230 V; 50 Hz / 230 V; 60 Hz				
	(kW)	1.4	3.2	3.2	3.2	3.3
		Protection Class 1 to VDE 0106				
Units are conform to EU Guideline 89/336/EWG (EMC) and 73/23/EWG (low-voltage) and carry the CE mark (230 V; 50 Hz).						
Cat. No. compl. with R 400-P						
230 V; 50 Hz		LTB 139	LTB 136	LTB 137	LTB 138	LTB 142
230 V; 60 Hz		LTB 239	LTB 236	LTB 237	LTB 238	LTB 242

*) see Item 4.3

Technical changes reserved.

LAUDA Ultra-Thermostats
 UB 20(-D), UB 25, UB 50,
 UB 20 F, UB 20 J, UB 30 J, UB 40 J, UB 65 J
 UB 20 JL, UB 30 JL, UB 40 JL

Technical data to DIN 58966

		UB 20 JL	UB 30 JL	UB 40 JL
Operating temperature range (with external cooling)	(°C)	-40...200	-40...200	-40...200
Working temperature range Simplex	(°C)	45...200	45...200	45...200
with water cooling	(°C)	20...200	20...200	20...200
Temperature sensor		Pt 100 Class B to DIN EN 60751		
Temperature variation at 70°C in the bath	(°C)	± 0.005... ± 0.01*		
Heater power (max.)	(kW)	3	3	3
Safety system		2nd resistance thermometer and level sensor		
<u>Simplex pump</u>				
Pump output against zero head				
(outside the bath)	(l/min)	15	15	15
Pump pressure (max.)	(bar)	0.3	0.3	0.3
Pump connections		M 16 x 1; nipples 13 Ø		
Filling volume	(l)	15...18	22.5...30.5	32...40.5
Bath opening	(mm)	Ø 195		
Bath depth	(mm)	195	320	450
Usable liquid depth	(mm)	175	300	430
Height to top of bath	(mm)	265	390	520
Bench area (W x D) x Height (only thermostat)	(mm)	(300x450)x465	(300x450)x465	(300x450)x590
Weight (with R 400-P)	(kg)	27	33	39
Supply		230 V; 50 Hz / 230 V; 60 Hz		
	(kW)	3.2	3.2	3.2
		Protection Class 1 to VDE 0106		
Units are conform to EU Guideline 89/336/EWG (EMC) and 73/23/EWG (low-voltage) and carry the CE mark (230 V; 50 Hz).				
Cat. No. compl. with R 400-P				
230 V; 50 Hz		LTB 143	LTB 144	LTB 145
230 V; 60 Hz		LTB 243	LTB 244	LTB 245

*) see Item 4.3

Technical changes reserved.

2.2 Controller R 400-P

Ambient temperature	(°C)	5...40
Control range	(°C)	-65...305
Temperature setting/ Resolution	(°C)	membrane keypad with 16 keys, setpoint input with 0.01°C resolution
Temperature measurement (bath)		built-in digital thermometer with 0.01°C resolution; accuracy and stability of measurement (electronics without probe) better than 0.05 % ± 0.05 K*). Temperature probe Pt 100 to DIN IEC 751, Class B, can be calibrated additively at each measurement point.
External temperature measurement		2 separate temperature measurement circuits for external Pt 100 to DIN EN 60751 in 4-wire circuit, accuracy and stability of measurement better than 0.05 % ± 0.05 K*), can be calibrated additively at each measurement point. One probe produces the measurement for external control.
Display		back-lit LCD matrix display, 2 lines with 16 signs each, 10 mm character height
Temperature control		modified PID controller with automatic structure selection. Control parameters through auto-adaptation or manual input. With external control a cascade controller operates on the measurement of one of the two external circuits (T1 or T2).
Heating actuator		triac zero crossing with full wave PWM, capacity max. 3 kW or 14 A
Triggering for controlled cooling		triac control of control valve for cooling water solenoid valve 230 V; 50/60 Hz, max. 0.2 A
Safety devices		In the working temperature range adjustable overtemperature protection and adjustable low-level protection. Pump and heater are switched off on all poles.
Overtemperature measurement		Pt 100 in the thermostating part
Terminal strip for interface		overall fault, input fault, analogue signals, 2 x Pt 100 Ext
Digital interface		RS 232 C
Bench area (W x D x H)	(mm)	190 x 200 x 180
Weight	(kg)	4
Supply		230 V; 50/60 Hz
Loading (max.) without accessories		3.2 kW
current take-up (max.) with accessories		16 A
Cat. No. (only if controller is ordered separately) R 400-P		LRK 013

*) see Item 4.3

Technical changes reserved.

LAUDA Ultra-Thermostats
UB 20(-D), UB 25, UB 50,
UB 20 F, UB 20 J, UB 30 J, UB 40 J, UB 65 J
UB 20 JL, UB 30 JL, UB 40 JL

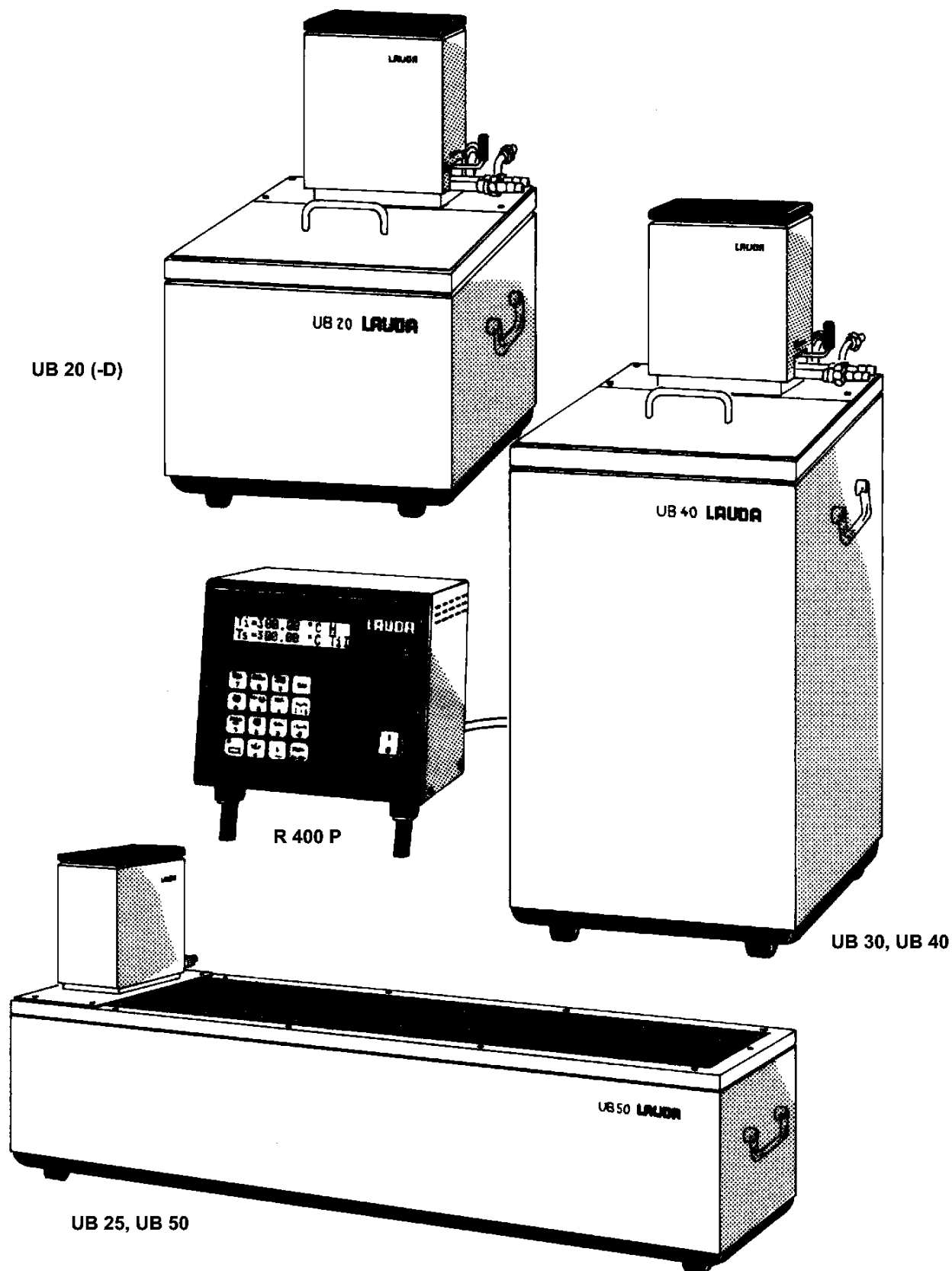

LAUDA Ultra-Thermostats
UB 20(-D), UB 25, UB 50,
UB 20 F, UB 20 J, UB 30 J, UB 40 J, UB 65 J
UB 20 JL, UB 30 JL, UB 40 JL

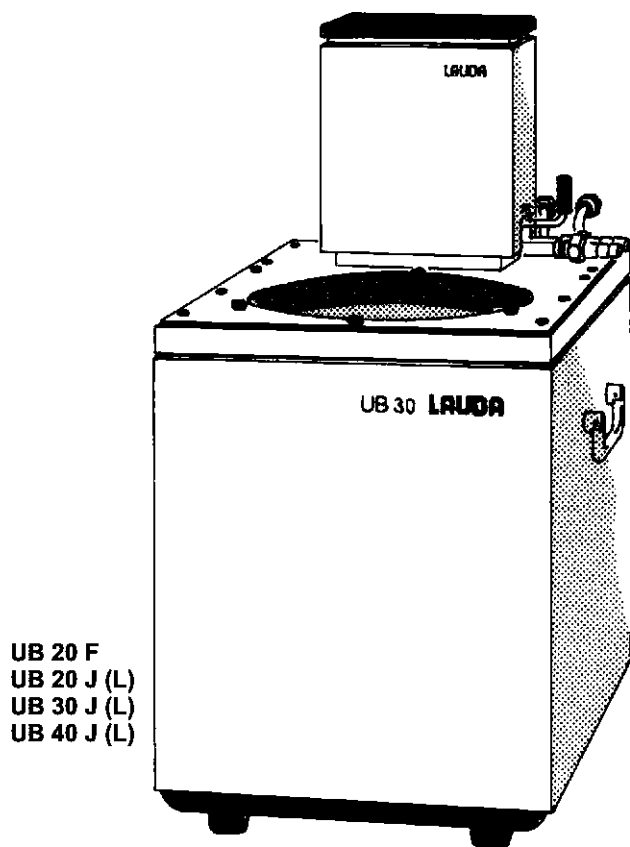

UB 20 F
UB 20 J (L)
UB 30 J (L)
UB 40 J (L)

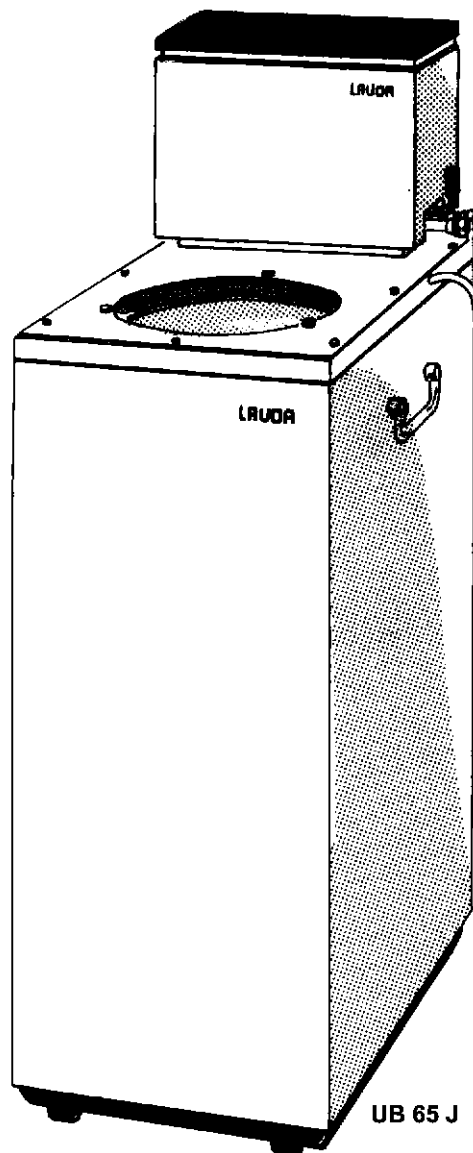

UB 65 J

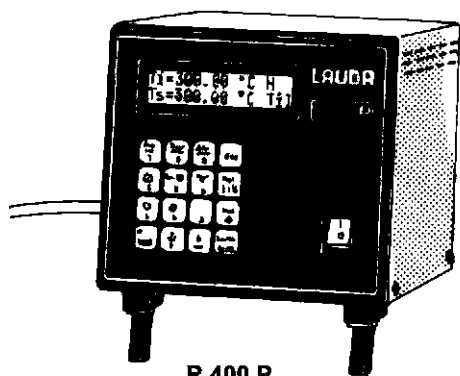

R 400 P

LAUDA Ultra-Thermostats
 UB 20(-D), UB 25, UB 50,
 UB 20 F, UB 20 J, UB 30 J, UB 40 J, UB 65 J
 UB 20 JL, UB 30 JL, UB 40 JL

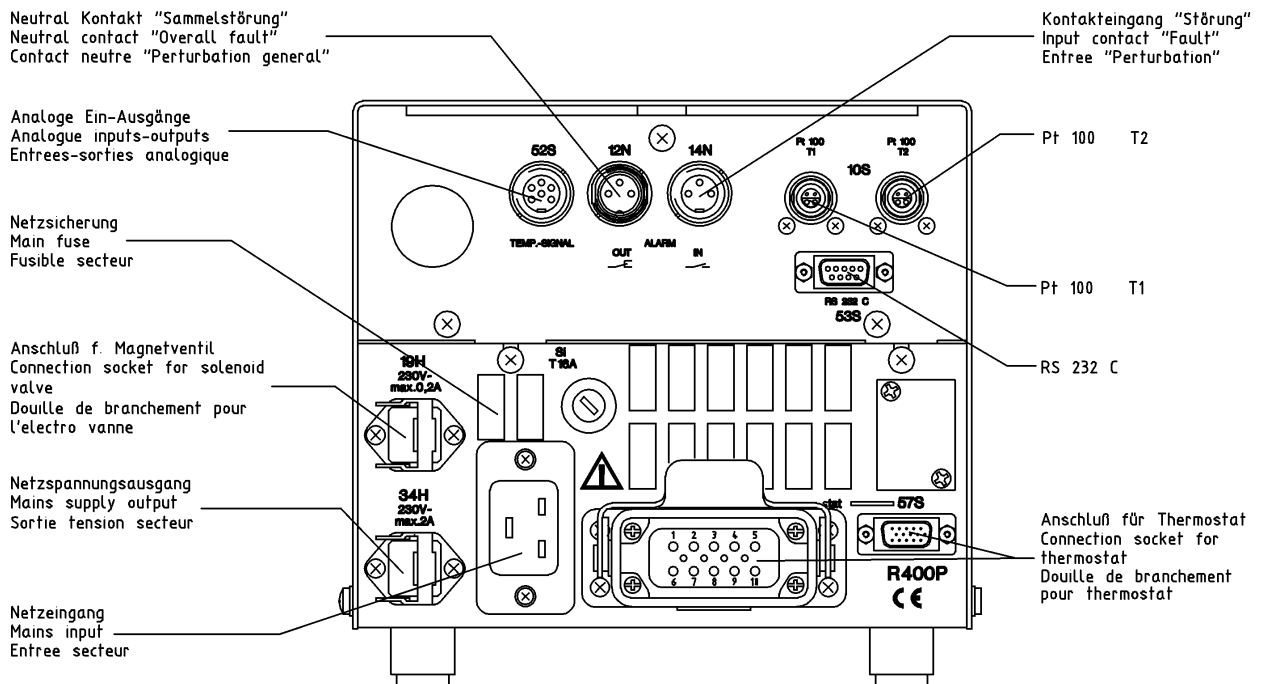
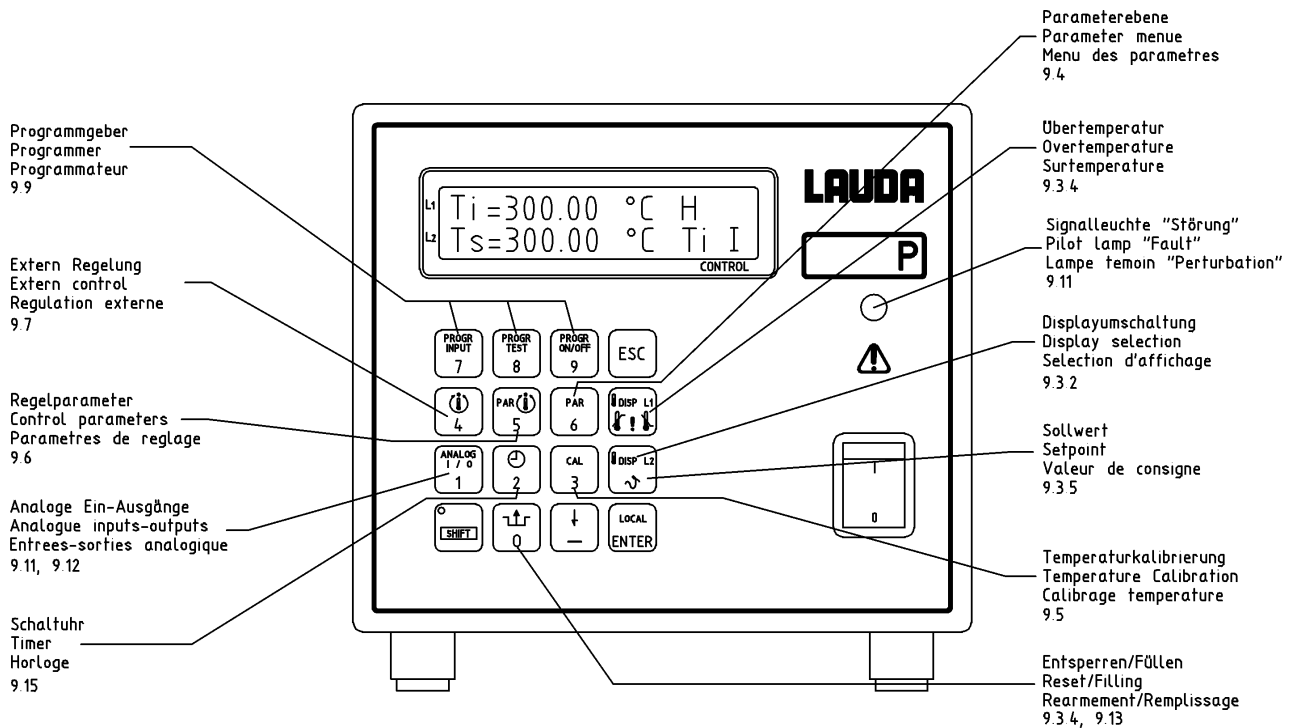

3 General construction and technical description

3.1 *Operating principle and type characteristics*

A special feature of all LAUDA Ultra-Heating Thermostats is the separation of the thermostat with bath, pump and all functional elements in contact with the bath liquid from the control unit R 400 P which also contains the whole electronics. The connection is done through two separated cables for mains voltage and low-voltage.

Type characteristics

UB 20, UB 25, UB 50, UB 30 and UB 40: rectangular bath/circulation thermostats of different dimensions and volumes. UB 20 alternatively with Simplex or Duplex pumps (UB 20-D).

UB 20 F: for testing and calibrating clinical thermometers and their capillaries. One of the remarkable features of this unit is the very low limitation of the working temperature range which enables the typical temperatures between 37°C and 42°C without cooling and with a very high temperature accuracy. The heater and pump capacities are brought into line correspondingly.

Apart from that like UB 20 J

UB 20 J, UB 30 J, UB 40 J and UB 65 J: All models are equipped with a cylindrical operating chamber which is adjustable approx. 20 mm in height. By this facility the bath surface can be adjusted so that it can even be above the cover plate. Thus fully immersed thermometers can be read directly at the immersion place. Additionally the separate operating chamber offers a constant immersion depth independent of the volume expansion of the bath liquid and a very good temperature accuracy and temperature distribution. All units are also provided with pump outlets for connecting up closed external thermostating systems.

UB 20 JL, UB 30 JL, UB 40 JL These models are equipped with polyurethane foam. Thereby the temperature range is specified from -40 to 200 °C.

Type UB 65 J is equipped with two circulation pumps because of the great liquid volume.

Example UB 20 J:

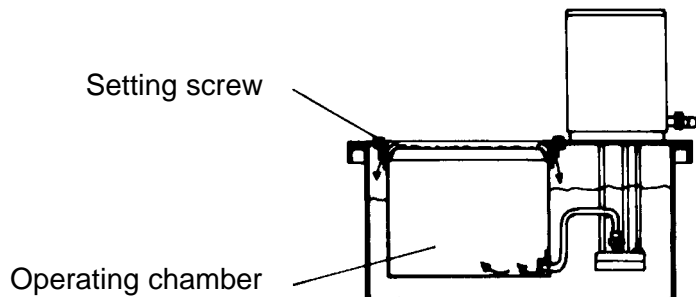

Laboratory thermostats operate with liquids (operating medium, heat transfer oil) which serve for energy transfer to the product to be thermostated.

The thermostated products can be immersed in the thermostatic bath (bath thermostat), or placed in an external open bath circulated by the pump of the thermostat.

When operating as a circulator the thermostatic liquid is pumped through an external heat exchanger arranged by the user in which a product is being thermostated (jacketed vessels, reactors, heat exchangers).

3.2 Materials

All materials in contact with the bath liquid are made from rust-free stainless steel or materials of similar anti-corrosion properties.

3.3 Cooling coil

All units are fitted with a cooling coil which permits cooling, e.g. with water, for working temperatures in the range of the ambient temperature (see Item 4.4.5 and Section 8).

3.4 Pumps

The units are fitted either with a pressure pump (type designation without -D) which we call SIMPLEX pump or with a pressure/suction pump with automatic level control (type designation with -D) called DUPLEX pump. Both types are submersible centrifugal pumps.

SIMPLEX pumps have a single pressure stage; they are used for thermostating closed external systems or when the unit is used mainly as a bath thermostat.

DUPLEX pumps have a pressure stage and a suction stage. The output of the pressure stage is adjusted by a float in accordance with the bath level so that the two stages have the same output. This enables to thermostate external open baths. The pumps are driven by nonsynchronous outside rotor motors with overload protection embedded in the motor winding.

Both pump models are fitted with a lever for flow rate adjustment which can be used to vary the flow rate between zero and the maximum. The pumps operate perfectly with liquids up to a viscosity of approx. 150 mm²/sec., with increasing viscosity the pump output decreases rapidly.

Performance diagrams:
230 V/50 Hz

SIMPLEX - pump

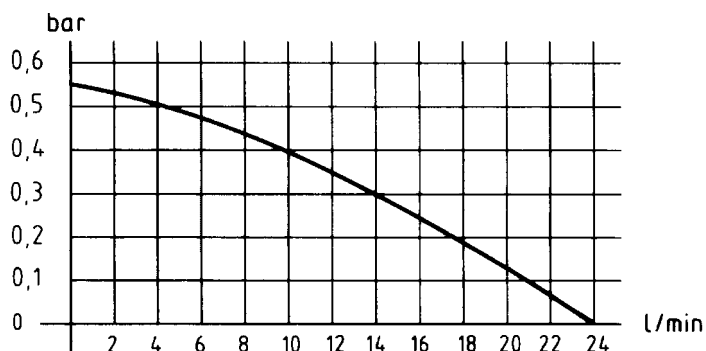

DUPLEX - pump

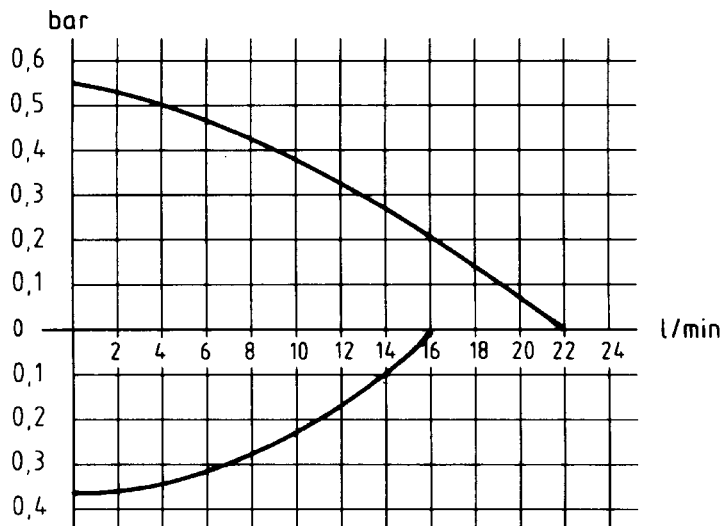

3.5 **Temperature control and electronics**

The units operate with a Pt 100 resistance thermometer for measuring the bath temperature (Ti). The bath temperature, all other temperature values and message signals as well as inputs are indicated as 2 x 16 characters (10 mm high) on a liquid crystal display (LCD) with background illumination. Input of the setpoint (Ts) and of all other parameters is made by using a membrane keypad with 16 keys and the operator guidance in the LCD display field. All inputs are stored even when the thermostat is switched off or if the supply fails.

The digitizing of the Pt 100 resistance signal is performed in the microprocessor by continuous comparison with precision resistors. The secondary control using a modified PID control algorithm is purely digital. The tubular heater for the heating of the bath is then operated electronically using a triac with burst firing action.

The tubular heaters have a surface loading of approx. 6 W/cm².

3.6 Mains supply output 34 H

The 230 V supply voltage is available at the socket 34 H at the back in normal operation and with the unit switched on. The maximum current which can be drawn there is 2 A. In case of a fault this supply is switched off. This output can be used e.g. to connect a through-flow chiller or a non-return fitting (Cat. No. UD 125).

Suitable mating plug

Cat. No. EQS 045

3.7 Controlled cooling

The units are equipped for controlled cooling to operate a solenoid valve which controls the cooling water flow. This provides fully automatic cooling (20...100°C). It ensures faster heating up (compared to continuous cooling), greatly reduced water consumption and improved temperature control during heat dissipation since the heater does not operate against the cooling action.

Voltage output (19 H) 230 V; 50/60 Hz max. 0.2 A.

Solenoid valve for cooling water control

Cat. No. UD 085

4 Safety devices and warning notes

4.1 Safety functions

The built-in overtemperature limiter can be set over the complete operating temperature range.

The bath temperature is measured by a separate Pt 100 resistance sensor (T_{Si}) and processed by a separate analogue/digital converter. This measured value is compared with the measured value of the bath temperature probe (T_i) continuously. If the measurements differ by more than ± 15 K the thermostat switches off as in the case of a low-level or overtemperature fault.

The function of the microprocessor is monitored by an integrated watchdog circuit and an additional counter which operates similarly to a normal watchdog circuit but is also capable of switching off the unit in case of a strobe failure.

When the set overtemperature switch-off point (T_O) is exceeded the unit switches off permanently on all poles.

A float switch with magnetic coupling acts as a low-level cut-out and also switches off the unit (pump and heater) permanently on all poles.

In both fault conditions the display indicates the corresponding message and additionally an audible signal draws attention to the fault. The switch-off function of the safety circuit remains stored even during a break in the supply or after having switched off the supply.

Reset is possible by pressing the reset key , but only after having eliminated the troubles.

The pump motor is fitted with a temperature monitor which switches off if the motor winding overheats. The heater is also switched off simultaneously. After the motor winding has cooled down the pump starts up automatically.

4.2 *Why can a thermostat be dangerous?*

1. Thermostats are equipped with heaters supplying the necessary heat to the thermostating liquid. If the temperature control fails or if the liquid level is too low, the heater may reach temperatures which can lead to a fire in the laboratory, especially in combination with flammable liquids.
2. When using the thermostat as a circulation thermostat a hose may break, causing hot liquid to spill and endangering people and goods.

The safety requirements on thermostats therefore depend on whether

- o non-flammable or flammable liquids are used
- o operation is with or without supervision

The thermostats described in these Operating Instructions are protected against overtemperature and low liquid level (FL) when operated according to the regulations.

The units can be operated with non-flammable bath liquids and with flammable bath liquids up to 25°C below their fire point (EN 61010) on condition that there is a correct adjustment and regular testing (see Item 9.13) of overtemperature and low-level protection.

4.3 *Important notes*

The user is only protected against those hazards which are caused by exceeding the temperature and by low liquid level.

Further hazards may arise from the type of product being thermostated, e.g. a shift above or below certain temperature levels or a fracture of the container and a reaction with the thermostatic liquid, etc.

It is impossible to cover all possible causes, and they remain largely within the decision and responsibility of the user.

Values for temperature variation and indication accuracy apply under normal conditions according to DIN 58966. In special cases high-frequency electromagnetic fields may lead to less favourable values. There is no loss of safety.

Note: The units must only be used according to the descriptions indicated in these Operating Instructions.

This includes operation by properly qualified and instructed personnel

The units are not designed for operation under medical conditions according to EN 60601-1 or IEC 601-1!

4.4 Warning notes

4.4.1 Temperatures

Parts of the bath cover may reach temperatures above 70°C when working at higher temperatures. The outflow and return pipes of the pumps reach the operating temperature. Touching them is dangerous because of very high or low temperatures!

4.4.2 Mains connection

Connect the unit only to mains sockets with protective earth contact (PE) which must not have a fuse higher than T 16 A.

4.4.3 Mains cable and connecting cables

We have ensured that the mains cable, the connecting cables and other plug connections do not touch any hot parts. Please check that there is no contact between the connecting tubings filled with hot liquid or other hot parts and the mains cable.

4.4.4 Fume extraction

Depending on the bath liquid used and the operating method there is a possibility that toxic vapours may be produced. In that case it is necessary to provide an appropriate fume extraction. Pull out the mains plug before cleaning the bath with solvents. Provide appropriate fume extraction. Before starting up the unit it is absolutely essential to ensure that the bath contains no explosive mixture. If necessary purge it with nitrogen!

4.4.5 Cooling water, steam production

Use cooling coils with cooling water only at operating temperatures below 100°C; at higher temperatures there is a danger that superheated steam may be produced. When changing the bath liquid from water to heat transfer fluids for temperatures above 100°C any remaining water - including the one in the hoses and external system - has to be removed completely.

Otherwise there is a danger of burns because of delayed boiling.

5 Bath liquids and hose connections

The operating temperature ranges of the bath liquids and hoses are for general information only and may be restricted through the operating temperature range of the units or the safety requirements specified in the appropriate standards (see Item 4.2).

5.1 Bath liquids

Operating temperature range 5...90°C

Use softened water. Make up evaporation losses at elevated temperatures. Losses can be reduced by providing suitable bath covers (see accessories).

Distilled or deionised high-purity water is corrosive and should be used only with the addition of about 0.1 g sodium carbonate per litre water. Otherwise its use may lead to corrosion.

Temperatures near zero and below:

Water - monoethylene glycol mixture, preferably Glycoshell P 300, in the ratio 1:1

Kryo 30 (former designation: Ultra-Therm G 100)

Cat. No. LZB 009

working temperature range	-30...90°C
boiling point	110°C
viscosity at 20°C	4 mm ² /sec
non-flammable	

When operating for longer periods at higher temperatures the proportion of the water decreases. The mixture approaches the properties of pure glycol and becomes flammable (flash point 128°C). The mixture ratio should therefore be checked from time to time against the original mixture, e.g. by using a hydrometer.

working temperature range 30...200°C

Ultra 350 (former designation: Ultra-Therm 330 SCB)
(synthetic heat transfer oil)

Cat. No. LZB 007

viscosity at 20°C	34 mm ² /sec
fire point	>240°C

working temperature range 80...280°C

Ultra 300 (former designation: Ultra-Therm SW 300 N)
(Silicone oil)

Cat. No. LZB 008

viscosity at 80°C	30 mm ² /sec
viscosity at 100°C	20 mm ² /sec
fire point	>400°C

LAUDA Ultra-Thermostats
UB 20(-D), UB 25, UB 50,
UB 20 F, UB 20 J, UB 30 J, UB 40 J, UB 65 J
UB 20 JL, UB 30 JL, UB 40 JL

working temperature range -20...180°C

Kryo 20 (former designation: Ultra-Therm 160 MS)
(Silicone oil)

Cat. No. LZB 016

viscosity at 20°C	10 mm ² /sec
viscosity at -30°C	34 mm ² /sec
fire point	>230°C

Safety data sheets according to EU Guidelines are available on request.

5.2 *Hose connections*

5.2.1 *Perbunan tubings*

Perbunan tubing, uninsulated

Cat. No. RKJ 011

9 mm int. diameter. Temperature range 0...120°C.
Suitable for all bath liquids listed above

Perbunan tubing, insulated

Cat. No. LZS 004

9 mm int. diameter, approx. 30 mm ext. diameter.
Temperature range -60...120°C.
Particularly suitable
for low-temperature operation

Perbunan tubing, uninsulated

Cat. No. RKJ 012

11 mm int. diameter.
Temperature range 0...120°C.

Perbunan tubing, insulated

Cat. No. LZS 008

11 mm int. diameter, 9 mm insulation
Temperature range -60...120°C.
Particularly suitable for low-temperature operation.

5.2.2 Silicone tubings

Silicone tubing, uninsulated Cat. No. RKJ 059

11 mm int. diameter. Temperature range -30...100°C.
For water and water-glycol mixture.

Silicone tubing, insulated Cat. No. LZS 007

11 mm int. diameter
9 mm insulation.
Application as for uninsulated Silicone tubing.
Temperature range -60...100°C.

Note: Do not use Silicone tubing in conjunction with Silicone oils !

5.2.3 Metal hoses

Metal hoses (single-layer insulation)

Temperature range 0...400°C

Metal hose MC 50	(50 cm long)	Cat. No. LZM 040
Metal hose MC 100	(100 cm long)	Cat. No. LZM 041
Metal hose MC 150	(150 cm long)	Cat. No. LZM 042
Metal hose MC 200	(200 cm long)	Cat. No. LZM 043

Metal hoses with special insulation (3-layer insulation)

Temperature range 0...350°C

Metal hose MC 50 S	(50 cm long)	Cat. No. LZM 046
Metal hose MC 100 S	(100 cm long)	Cat. No. LZM 047
Metal hose MC 150 S	(150 cm long)	Cat. No. LZM 048
Metal hose MC 200 S	(200 cm long)	Cat. No. LZM 049

Metal hose connections, to link pump outlets (insulated) Cat. No. LZM 044
Temperature range 0...400°C

Highly-flexible, thermally insulated stainless steel (V2A) metal hoses with M 16 x 1 mm connecting thread. Int. diameter 10 mm. These hoses offer optimum safety.

Further details on thermostatic liquids and hoses can be found in our special publication.

6 Unpacking, assembly and setting up

6.1 Unpacking

The goods are packed carefully, largely preventing transport damage. If unexpectedly some damage is visible on the equipment please inform the carrier or the postal authority so that it can be inspected.

Standard accessories

1 Bath cover	Cat. No. HDR 001	for U 3, USH 6, USH 12
1 Bath cover	Cat. No. HDR 023	for U 6(-D), US 6(-D)
1 Bath cover	Cat. No. HDR 022	for U 12(-D), US 12(-D)
1 Bath cover	Cat. No. HDQ 045	for UB 20(-D), UB 30, UB 40
1 Ball-form condenser	Cat. No. EG 002	for USH 6, USH 12
4 Nipples 13 mm dia.(fitted)	Cat. No. HKO 026	
2 Nipples 11 mm dia.	Cat. No. HKO 025	
4 Screw caps (fitted)	Cat. No. HKM 032	
1 m Perbunan tubing (11 mm int.dia.)	Cat. No. RKJ 012	
1 Controller R 400 P	Cat. No. LRK 013	
1 Mains cable for R 400 P	Cat. No. EKN 012	

Operating Instructions

6.2 Setting up, operation as bath thermostat

Set the thermostat and the controller R 400 P next to each other.

Make the connections between the thermostat and the control unit (45 H to 40 H and 61 S to 57S) and lock the plugs.

Insert the mains cable into the socket 12 H of R 400 P.

Ensure a minimum spacing of 20 cm between the grille at the rear of the unit and the wall so that the air circulation through the grille is not restricted.

Close the drain cock at the back or side of the bath!

When operating as a bath thermostat - no external system connected up - link the pump connectors together with a piece of tubing.

As a permanent arrangement the hose link of flexible insulated metal tubing (Cat. No. LZM 044) is the best and safest solution.

Open the pump adjusting lever to improve the circulation within the bath.

UB 65 J is fitted with an overflow connection (below the pump connectors). Here the hose is connected. Place a suitable vessel below it.

Note: When loosening or tightening the screw caps (19 mm a/f), hold the threaded nipple on the tubing connections with a spanner (14 mm a/f)!

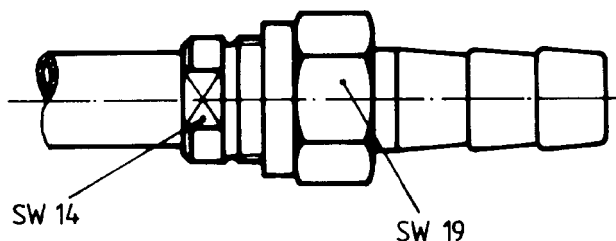

7 Connection of external systems

7.1 Circulation pumps

In principle there are two different pump types:
SIMPLEX pumps, e.g. at UB 20, US 12 and
DUPLEX pumps, e.g. at UB 20-D, US 12-D.

SIMPLEX pumps are used for operation with closed external systems. They require a pressure-tight external system.

DUPLEX pumps are used mainly with open external systems, such as bath vessels. In contrast to SIMPLEX pumps they have a pressure and a suction stage as well as a float for level control. DUPLEX pumps automatically maintain a constant level in the thermostat irrespective of the level in the external bath. Liquid is poured into the external bath until a level is achieved in the thermostat at which the pressure and suction stages have exactly the same output.

7.2 Closed external circuits

If the thermostat is connected to closed external circuits, additional liquid must be poured in after the thermostat has been switched on until the liquid in the bath remains at the correct level (approx. 2 cm below the cover plate).

At higher operating temperatures the expansion in volume of approx. 8% per 100°C during the filling has to be taken into account.

For suitable tubing materials see Section 5.
We recommend metal hoses for temperatures above 100°C.

With external systems at a higher level it may happen even in closed circuits that the external volume drains down and the thermostat bath overflows if the pump is stopped and air enters the thermostated system!

Always ensure the maximum possible flow area in the external system (nipples, tubing, system). This results in a larger flow and therefore improved thermostatic control.

Note: Always protect the tubing with hose clips against slipping off, or use stainless steel hoses (V2A) with screwed connections.

7.3 **Open systems (baths)**

Units with a pressure/suction pump can be used for thermostating external open baths.

For thermostating open external systems (baths) hang the hoses into the external bath, preferably at opposite sides, and protect them against slipping out.

The suction hose should have a notch at its end so that it cannot attach itself by suction to the wall or the bottom of the bath. Using a screw-on connector (Cat. No. UO 062) is a better solution.

Before switching on the unit the external bath has to be filled with liquid up to the required level.

It is advisable to set up the external bath at the same level.

If the difference in level between the open external bath and the thermostat bath is more than 0.5 m there is the possibility in certain applications that the control range of the level controller is not sufficient. With a higher (lower) external bath level the suction (pressure) hose should then be clamped off to such an extent that a constant level in the bath is obtained at which the float is within its control range.

Note: If the thermostat and the external bath are not at the same level it is essential to provide the venting of the connecting hoses when the pump is switched off in order to prevent overflowing.

It is preferable to use the Non-Return Fitting (see accessories) which is mounted at the highest point of the hose connection (bath or thermostat connection) and which is linked electrically to the mains output 34 H.

Non-Return Fitting

Cat. No. UD 125

Always protect the tubing with hose clips against slipping off, or use stainless steel hoses (V2A) with screwed connections.

Note: When tightening the screw caps (19 mm a/f) at the tubing connections, hold the threaded nipple with a spanner (14 mm a/f)!

8 Cooling the thermostats

Because of the frictional heat of the circulating pump, thermostating without cooling can only start appreciably above the ambient temperature (see Technical data, working temperature range, lower limit). For lower temperatures it is essential to work with cooling.

The following possibilities are available for cooling:

8.1 Mains water cooling

Depending on the water temperature down to 15°C. The thermostats are equipped with a cooling coil (at the rear) which is linked by tubing to the water tap and to the drain. The flow should be kept as low as possible; this saves water and improves the temperature control. Controlled cooling is possible when using a solenoid valve (see Item 3.7)

8.2 Through-flow chillers DLK 10, DLK 25 and DLK 45

Can be used, depending on the thermostat type, down to -10°C (DLK 10), -30°C (DLK 25) or -40°C (DLK 45). Use insulated hoses for the connection between the flow and return connections of the pump and the nipples of the through-flow chiller. If the thermostat operates in a closed external circuit the chiller is connected in series in the return line from the external system to the thermostat.

Always use water-glycol mixture (ratio 1:1).

9 Starting up

9.1 *Filling*

Fill the unit with bath liquid to suit the operating temperature, see Section 5. The filling volume is given under Technical data. In general the thermostat must be filled no higher than 2 cm below the cover plate. When working with thermal oils (e.g. Ultra-Therm 330 SCB) slightly less liquid should be filled in to allow for expansion. The level must obviously not fall below the minimum, otherwise the low-level protection switches off the unit (see Safety circuit). The same applies to filling an external system by the pump during start-up.

UB 20 F, UB 20 J, UB30 J, UB 40 J, UB 65 J

When these types are switched on the cylindric working chamber is always filled completely, this is why only the rest volume of the bath allows for further expansion in volume.

We recommend to control the level at operating temperature with the unit switched off. Also in this case the level should not be higher than 2 cm below the cover plate.

9.2 *Connection to supply*

Connect the unit only to an earthed socket (PE). Compare the details on the label with the mains voltage (see Item 4.4.2).

Model according to EMC directive EN 61326-1 (industrial areas only). *

When working without external system, ensure that the pump connections are linked together (metal hose link Cat. No. LZM 044) or closing plugs are being used.

9.3 *Basic functions*

9.3.1 *Supply switch-on*

Switch on the mains switch. The green indicating lamp lights up. The display shows consecutively

Fa LAUDA
P-Thermostat

Type R 400 P
V 2.XX Date

L1 Ti = 20.00°C C
L2 Ts= 10.00°C Ti I



for all Ultra-Thermostats
software version

other values depending on
bath temperature and setpoint

* Notice only valid for EU countries!



9.3.2 Standard display

Top line L1



Ti	=	bath temperature (i = internal)
C	=	output in cooling range
H	=	output in heating range
	=	cooling indication proportional to cooling actuation control
	=	heating indication proportional to heating actuation control

Bottom line L2

Ts	=	setpoint temperature (S = setpoint)
Ti	=	control variable is Ti (bath temperature), can be switched to T1 or T2 (ext. Pt 100)
I	=	setpoint source (I = internal = input from keys, P = programmer, R = from RS 232 C, A = analogue input socket 52 S)

The display in line 1 (L1) can be switched by pressing the keys   and repeated operation of  to T1, T2, Ti etc.

T1, T2 = measurements of external Pt 100 probes

The display in line 2 (L2) can be switched by pressing the keys   and repeated operation of  to

Y = actual output + heating - cooling

Tsi = measurement of safety comparison probe with limited resolution and accuracy

Ti, T1, T2, Ts etc.

9.3.3 Basic action on inputs and outputs

From virtually every display or input function the key  aborts and returns to the selected standard display!

Numerical inputs are always made with the SHIFT function switched off (LED in SHIFT key off)!



After the last digit of a number the cursor returns to the first digit so that corrections can easily be made before pressing the  key.

A brief beep on pressing a key means that this input is not possible!

Error messages are indicated with text notes and accompanied by a beep. After approx. 5 sec the message disappears and the beep switches off.

9.3.4 Overtemperature switch-off point



Press the  key to indicate the current overtemperature switch-off point (To).

Important: The green LED in the  key must not be alight. If necessary bring the keypad to the basic mode by pressing the  key (LED off). If Tu is indicated, press  again to indicate To.

L2 To: _95.00 Ti I



To = overtemperature switch-off point

To can be selected within the unit temperature range + 5 K.

Return to the standard display without change with . A new value is input with the number keys (SHIFT, off); e.g. 98.70°C requires 0, 9, 8, 7, 0 . After the last digit the cursor returns to the first digit again so that any corrections can easily be made.

Pressing the key . Enter you are asked

L2 To new Y/N 1/0__(0)

Here the changed value must be confirmed with input  or, if no modification is requested, the initial value can be unscrambled again with input . As default value 0 is preset.

This interrogation was introduced in order to reach an additional protection from unintentional adjusting of the over-temperature switch-off point.

It is obviously essential to select a value above the current bath temperature (T_i) and the current setpoint (T_s), otherwise the equipment is switched off by the safety circuit with

L1 TEMPERATURE
 L2 TOO HIGH!

or the message



L2 $T_s \gg T_o$

and the value is not accepted.

With activated outflow temperature limit T_{io} T_o must always be 5°C higher than T_{io} . Otherwise announcement



$T_{io} \gg T_o - 5^\circ\text{C}$.

If the unit was switched off in the fault status an audible signal reports the stored fault when switching on.

Press the reset key . Depending on the previous sequence press  again.

If necessary check whether the overtemperature switch-off point T_o is above the current bath temperature and whether the bath is filled sufficiently !

9.3.5 Low temperature switch-off point

Press the key  (SHIFT OFF) to indicate the current low temperature switch-off point T_U . If T_o is indicated press  again to bring T_U on the display.

L2 T_U : $_{-}10.00^\circ\text{C}$

T_U = low temperature switch-off point

T_U can be set up to 10 K below the working temperature range of the unit.

If the bath temperature falls below T_U , T_U appears on the display in L2 so that a new value can be input if necessary. T_U operates as a setpoint limitation and as a signal.



9.3.6 Setpoint input

Press the  key (SHIFT LED off). L2 shows

L2 Ts: _ 20.00°C Ti I

The setpoint (Ts) can be input within the unit temperature range but not higher than the current overtemperature switch-off point. When the input is too high, pressing  does not enter the value but instead produces the message

L2 Ts >> To

Input Ts with the number keys incl. negative sign (SHIFT OFF), e.g. for -25.03°C input -, 2, 5, 0, 3 . Or for 1.93°C input 0, 0, 1, 9, 3 . After the last digit the cursor returns to the first digit again so that corrections can easily be made.

9.4 Parameter level PAR

Pressing the  key several times in the SHIFT mode (green LED in SHIFT key alight) leads successively to the input functions described below.

9.4.1 Auto-adaptation

Here it is possible to start the controller auto-adaptation by the input of 1 (SHIFT OFF) and pressing the  key.

There should be the largest possible difference between the bath temperature and the setpoint to be entered subsequently, i.e. the time to reach the setpoint has to be longer than 5 min, preferably 10 min. In addition, auto-adaptation is obviously possible only during a heating or cooling phase which is actively influenced by the energy sources available.

Example 1: intended operating temperature approx. 70°C:

1. set the setpoint to 70°C
2. within 1 minute start auto-adaptation at the PAR level, e.g. at a bath temperature corresponding to the ambient temperature

On reaching the setpoint the auto-adaptation switches off automatically, and the result of auto-adaptation can be indicated at the control parameter level  (see Item 9.6).

Example 2: it is required to operate at approx. 20°C with controlled cooling:

1. heat up the thermostat to approx. 60°C
2. set setpoint to 20°C
3. start auto-adaptation at the PAR level

9.4.2 Output limitation

Normally the maximum heating or cooling output is available. For special applications it is possible to set a limit for both heating and cooling output.



At the PAR level display select

L1 Output
L2 in per cent_ 100 %

Using  the display can be switched from e.g. 100%, i.e. heating output limitation, to cooling output limitation with a negative sign.

By the input of e.g. 0, 0, 5, 8 , SHIFT OFF, a heating output limitation of 58% can be set.

With e.g. -, 0, 9, 3  a cooling output limitation of 93% is entered.

The action can be recognised by the symbols  and  flashing even at large control deviations.

Only values between 10 and 100% or -10 and -100% can be entered, otherwise the display shows the message

L1 Output
L2 OUT OF RANGE

9.4.3 Display resolution L1

At the PAR level display select

L1	Display 0.001	= 1
L2	resolution 0.01	= 0

Entering 1 (SHIFT OFF)  switches all displays in L1 to 0.001 K resolution. The temperatures are then displayed with approx. 2 digit resolution. Input "0" switches all the displays in L1 to 0.01 K resolution.

Normally a resolution of 0.01 K is used.

9.4.4 Contact input Fault 14 N

When using the contact input "FAULT" 14 N, pins 1 and 2 of the socket have to be connected together when there is no fault. If this input is not being used, a blanking plug with a link has to be plugged in. The function of the contact input fault can be switched off at the PAR level on the display

L1	Alarm Inp. con 14 N
L2	on = 1 off = 0

by the input of "0" (SHIFT OFF). A shorting plus is then not required.

If the alarm input has been activated in error by the input of "1", the unit can be restarted by the following inputs:

Press the  key. At the PAR level select "Alarm Inp. con 14 N". Input "0" with .

Press  again.

If a fault message has been produced by opening the external signal circuit, reset by pressing the key  twice after rectifying the fault.

Connections contact input "Fault" 14 N (alarm in)

3-pin flange socket to NAMUR recommendation NE 28

1 = n.o. (close)
2 = common
3 = not used

Connector plug 3-pin

Cat. No. EQS 048

Contact load approx. 5 V 2 mA. No voltage must be connected!



Use shielded connecting cables. Connect the shielding to the plug case. Cover the unused connectors with protective caps!

9.4.5 Baud rate RS 232

On the display at the PAR level

L1 Ser. Int RS 232

L2 Baud Rate 9600

it is possible to switch with  between 9600 and 4800. With  (SHIFT OFF) the indicated baud rate is entered.

9.4.6 Menu language

On the display at the PAR level

L1 Lang. Germ = 0

L2 Engl = 1 French = 2

the menu language can be selected. Enter the corresponding code numbers 0, 1 or 2 with  (SHIFT OFF).

9.4.7 Calibrating the analogue output channels

The 90% values of the analogue voltage outputs channel 1 and 2 or the analogue current output of channel 1 can be calibrated separately for channel 1 (voltage or current) and channel 2 (voltage). The factory calibration on channels 1 and 2 for 0...10 V = -100...400°C is performed at 9 V = 350°C.

In special cases, e.g. to correct scaling deviations of instruments connected to the output, or if channel 1 is to be a current output, the output can be calibrated by the user.

At the PAR level display select

L1 Analogue outp Cal ?

L2 Chan 1 = 1 Chan 2 = 2

Input SHIFT OFF 1 , or 2 for channel 2.

Depending on the selected configuration of the analogue outputs (see Item 9.12) the socket 52 S (analogue signals, see Item 9.10) at pin 2 carries a voltage signal of approx. 95% or 9.5 V, or pin 5 the corresponding current signal of approx. 19 mA in case of current configuration for channel 1.

Using a precision multimeter or e.g. a temperature recorder set the output signal to 9 V or 18 mA or the corresponding temperature by the repeated operation of the key  (SHIFT ON).

Pressing  leaves the menu and the most recent value setting is entered.

If the value was selected too low, leave the PAR level with  and make a new selection.

The calibration of channel 2 is similar. Connect the measuring instrument to pin 1 (voltage signal only).

9.4.8 Operation with through-flow chiller DLK 45 with proportional cooling

At the PAR level display select

L1 DLK normal = 0

L2 DLK 45 auto = 1

Select „DLK normal“ by pressing 0 in order to have the function as already known of the two outputs 19 H and 34 H.

Select „DLK auto“ by pressing 1 in order to operate a through-flow chiller DLK 45 with automatic compressor control and proportional cooling; see also operating instructions of the through-flow chillers.

9.5 Calibration of the temperature measurement circuits

With the calibration function the indications of the three temperature measuring points bath temperature T_i , external Pt 100 probe T_1 and external Pt 100 probe T_2 can be set to a known accurate value. The resulting correction is processed additively over the entire temperature range.

Check first that a sufficiently accurate reference is available, otherwise it is better to use the factory calibration which gets lost by overwriting!

Pressing the key  in the SHIFT mode (green LED in shift key alight) produces the display

L1 CALIBRATE
L2 T_i = 0 T₁ = 1 T₂ = 2

The channel to be calibrated is selected with 0, 1 or 2 .

When selecting a channel not in use, e.g. if Pt 100 on T₂ is not connected, the display shows

L1 Ext Pt 100 not
L2 connected.

For calibration a sufficiently accurate reference temperature measurement should be possible, and the measurement point temperature should be constant.

The display shows

L1 T₁ 61.04°C
L2 T_c _ . °C

The value shown in L1 is the measured value obtained without any correction using probe and electronics without calibration.

Now enter the real value for the measurement point T₁ (e.g. 60.00°C):

Example 0, 6, 0, 0, 0 

T_i or T₂ can be calibrated in the same way.

In order to avoid dangerous conditions the correction is limited to ± 5 K. In case of larger corrections the display shows

L1 CORRECTION VALUE
L2 TOO LARGE

and the value entered is not accepted.

You can leave the calibration level with .

9.6 Control parameters

9.6.1 Indication and input of the control parameters

Pressing the key  several times in the SHIFT mode (green LED in shift key alight) shows the outflow temperature limitation, the correction limitation and the control parameters X_p , T_n and T_v on the display in L2.

Example:

L2	TiO:	<u>1</u> 20°C	Ti	I
L2	Td: _	30°C	Ti	I
L2	Xp: _	0.5°C	Ti	I
L2	Tn: _	12.0 s	Ti	I
L2	Tv: _	2.0 s	Ti	I

In order to use control parameters other than those found by the auto-adaptation (see Item 9.4.1) the values can be entered in the appropriate display after switching off the

SHIFT function, pressing , LED off.

Example for X_p :

0, 0, 1, 0 

if the required value is 1.0°C.

For values above 200.0°C or 200.0 sec the message

L2 OUT OF RANGE

appears.

9.6.2 Recommendations for the control parameters

In most cases satisfactory control results are obtained with the following control parameters:

bath liquid	water	oil
X_p	0,5°C	1°C
T_n	10 s	25 s
T_v	2 s	5 s

9.6.3 Bath temperature limitation

The limitation of the bath temperature is an additional warning and switch-off function switching off the heating at a selectable value; i.e. the heating output is set to "0". This protects the unit from a continuous cutoff via the safety circuit especially during external control at certain operating conditions.

To enter the switch-off point T_{iO} proceed as described in Item 9.6.1 and switch the display to input and indication.

Example: L2 T_{iO} 120°C

Change the value by entering the figures with a resolution of 1°C.

Enter the new value by pressing .

It is possible to select values within a range from 50°C to the selected overtemperature switch-off point $T_O - 5^\circ\text{C}$. If this range has not been respected the display shows the message

L2 T_{iO} >> $T_O - 5^\circ\text{C}$

Of course T_{iO} has to be set above the setpoint T_S ; otherwise the display shows the message

L2 T_S > T_{iO}

The bath temperature limitation can be switched off by entering

L2 T_{iO} 000

If the bath temperature T_i exceeds the selected switch-off point the display shows

Example: L2 T_{iO} 120°C

and there is an acoustic signal.

The heater switches off. As soon as the temperature has dropped the unit starts working again.

9.6.4 Correction limitation

During the operation with external control it may be necessary not to exceed the difference between the bath temperature T_i and the measuring point for the external control T_1 or T_2 , e.g. in order to get a smooth heating of the material or the vessel. Such a limit value can be selected by the variable T_d . If the value T_d is exceeded the heating or cooling output is set to "0". If this function is activated the time for heating up or cooling down may be extended.

To enter the difference value T_d proceed as described in Item 9.6.1, and switch the display to input and indication.

Example: L2 T_d $_30^\circ\text{C}$

Change the value by entering the figures with a resolution of 1°C .

Enter the new value by pressing .

It is possible to select values within the temperature range from 5°C to 150°C . If this range has not been respected the display shows

L2 OUT OF RANGE

and there is an acoustic signal. This function can be switched off by entering

L2 T_d 000°

9.7 External control

9.7.1 External measurement inputs and external controller

The units have two Pt 100 temperature measurement inputs whose measurements can be indicated (T_1 , T_2).

You can connect the external Pt 100 (T_1 , T_2) at the rear connectors 10 S in 4-wire circuit.

Use shielded connecting cables. Connect the shielding to the plug case. Cover the unused connectors with protective caps!

Pin connections sockets 10 S Pt 100

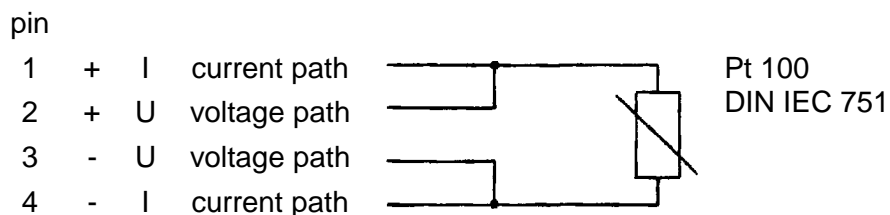

Plug, 4-pin Lemos, for Pt 100 connection

Cat. No. EQS 022

One probe can be selected for the actual value for external control. The unit then operates with cascade control to this actual value, i.e. the unit controls the temperature at the external measurement point to the selected setpoint by suitably altering the bath temperature. Thus the influence of disturbances (changes of load or through-flow, etc.) can be reduced considerably or eliminated totally.

9.7.2 Start of external control

Connect platinum resistance thermometers to both of the Pt 100 inputs 10 S (T1 and T2). It is sensible but not essential to use T1 if only one input is in use.

The external control with the measuring point T1 is switched on with the key  in the SHIFT mode; pressing the key again switches to T2 as control variable.

Pressing the key  once more (SHIFT ON) switches back to the bath control (internal) Ti.

In L2 the position before the final one shows the parameter used as control variable.

```
L2   Ts       = 120.35   Ti   |
                               T1
                               T2
```

This setting remains stored in case of a fault or after the power is switched off.

If T1 is selected but no probe has been connected the message

```
L1   Ext Pt 100 not
L2   connected
```

appears.

The unit then switches the control variable to T2 automatically. If T2 is also not connected, the thermostat switches to Ti.

When changing the setpoint for more than 10°C it may be possible to achieve an improved control result by re-starting the external control from the control variable Ti

(with SHIFT ).

After power OFF the unit operates with control from the bath (Ti) for safety reasons; external control must be re-selected after power ON as explained above.

9.7.3 Notes

When operating with external control it is essential to ensure that the probe for the control variable is in good thermal contact with the liquid, otherwise a poor control result must be expected, or the control may be completely ineffective.

Proceeding from the control parameters used for bath control the control may have to be adapted either by auto-adaptation (see Item 9.4.1) or by the input of the control parameters.

Important: Set the overtemperature switch-off point To (see Item 9.3.4) sufficiently high since the bath temperature may under certain circumstances become much higher than the setpoint.

9.8 **Working with controlled cooling**

Operation with controlled cooling requires a solenoid valve (see Item 3.7).

Insert the plug of the solenoid valve into the socket (19 H) on the back. The solenoid valve can be fitted either on the cooling coil or on a 1/2" water tap. Although fitting on the cooling coil is the usual method, mounting directly on the water tap is preferable for two reasons: When the valve is closed, the connection hose to the cooling coil is not under pressure; therefore there will not be a pressure surge when the valve is switched on, and the danger of the hose bursting is much reduced. Use hose clips!

With controlled cooling operation the solenoid valve switches with a cycle time of about

6 s. L1 indicates on the right the symbol  for the status of the solenoid valve.

Restrict the water flow as much as possible at the water tap. This produces improved control and saves cooling water.

Note: ensure that the cooling coil connectors  are used. Do not mix them up with the pump connectors!

It is essential to ensure free outflow from the cooling coil, especially at operating temperatures above 100°C because of steam formation! The use of controlled cooling is particularly helpful when initiating exothermal reactions or in programmer operation.

Solenoid valve for cooling water control

Cat. No. UD 085

Mating plug for other solenoid valve

Cat. No. EQS 005

Mounting instructions for the solenoid valve

Direct installation on the cooling coil (as supplied)

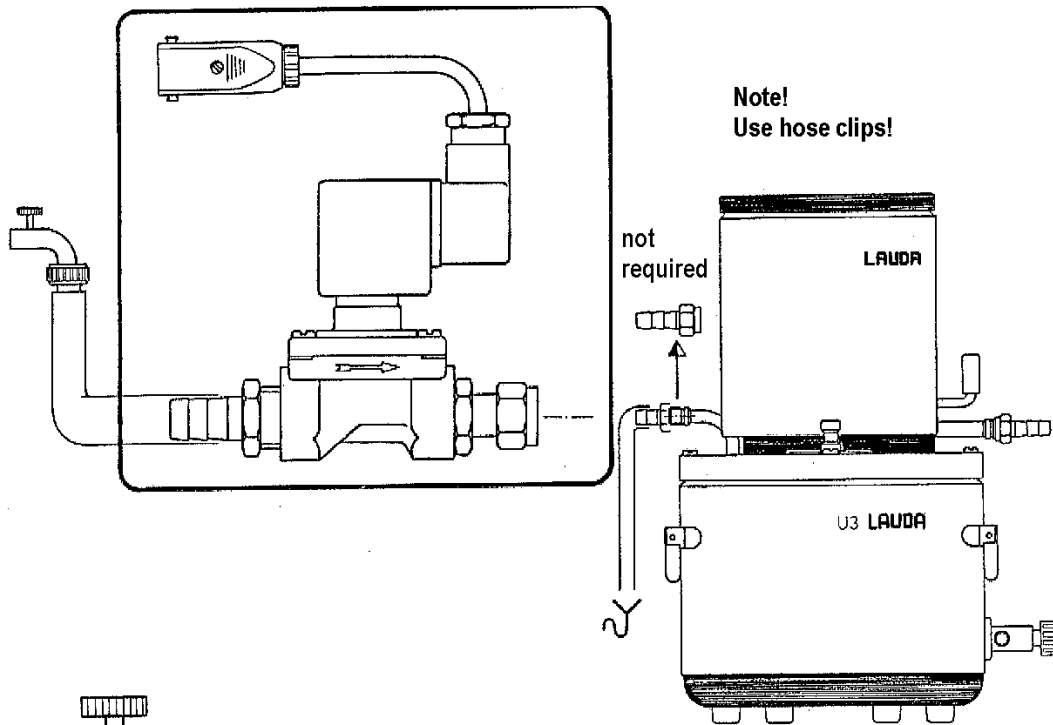

Direct installation at the water tap (modification)

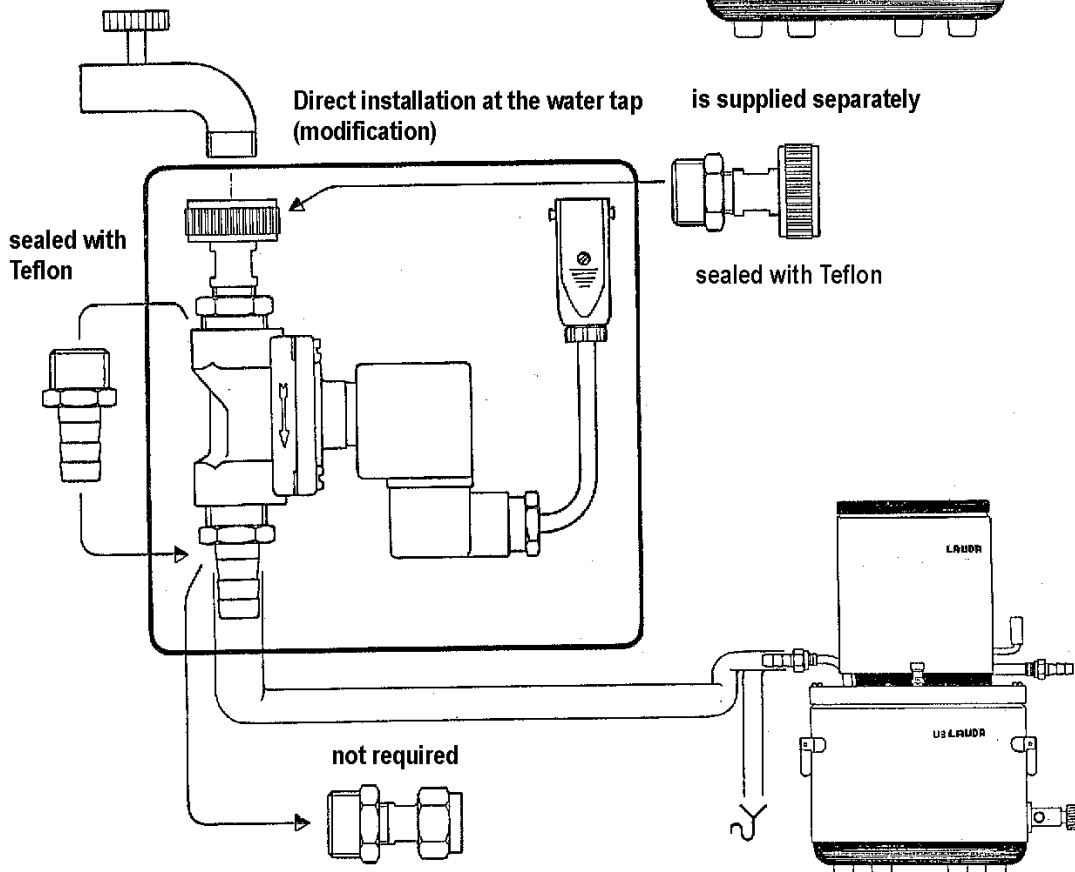

9.9 Operation with programmer

Temperature programmes with up to 99 segments can be stored and processed. A segment consists of a target temperature which is to be reached at the end of the segment, and the time duration of the segment. The time "00:00" for temperature differences is possible. In connection with the tolerance range monitoring the programme continues not until the target temperature is reached. It is useful to prepare a time-temperature diagram before programming and to check whether the energy balance enables the programme speed.

Set the overtemperature switch-off point T_0 to a value slightly above the highest bath temperature to be expected (see Item 9.3.4).

9.9.1 Programme input

Press the key  in SHIFT mode. The display shows

L1 PROG. INP
L2 Tstart:_. °C



Enter here the starting temperature of the programme. SHIFT OFF (automatically).

e.g. for 60.00°C input 0,6,0,0,0 .

The display shows

L1 PROG. INP SEG.01
L2 T:_. °C : h

Now enter the target temperature and the time for the first segment, e.g. for 140.00°C in the time 2 h 00 min

1, 4, 0, 0, 0  then 0, 2  then 0, 0 .

The display shows

L1 PROG. INP SEG.02
L2 T:_. °C : h

Now enter the target temperature and the time for the second segment, e.g. for a phase at a constant temperature 140.00°C and 1 h 30 min.

After the last programme segment press the key  once more.

The display shows

L1	PROG. INP
L2	NO OF CYCLES:_

Input 1 ... 99 is possible.

With more than one cycle it is convenient to have the final temperature and the starting temperature T_{start} at the same level!

Afterwards a tolerance range can be input for monitoring the programme.

The display shows

L1	PROG. INP
L2	TOL. RANGE_.

Now you can input a tolerance range value from 0.1 to 9.9°C. I.e. if the control variable (bath temperature or external temperature T_1 or T_2) deviates from the set temperature of the segment by more than the tolerance range value while the programme is running, the programme sequence will be stopped until the control variable is within the tolerance range again.

At the same time a "T" appears on the right in L2.

The input of 0.0 switches off the tolerance range function.

9.9.2 Example of a programme

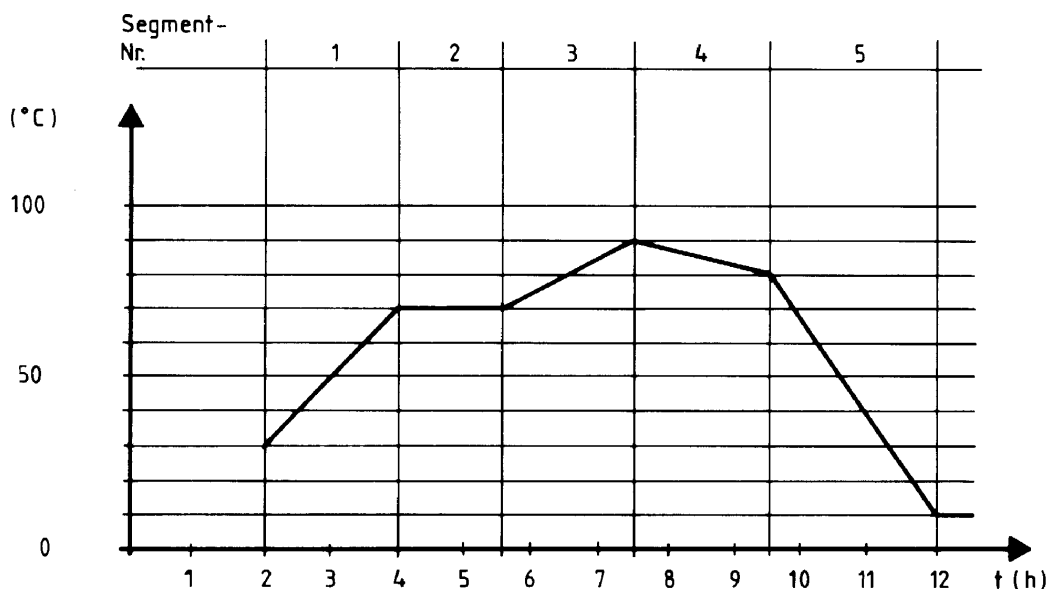

Segment-No.		Input	Press LOCAL ENTER
Tstart		03000	1x
1	°C	7000	1x
	h	02	1x
	min	00	1x
2	°C	7000	1x
	h	01	1x
	min	30	1x
3	°C	9000	1x
	h	02	1x
	min	00	1x
4	°C	8000	1x
	h	02	1x
	min	00	1x
5	°C	1000	1x
	h	02	1x
	min	30	2x
Cycles		1 ... 99	1x
Tolerance range	±°C	(0.0) 0.1...9.9	1x

9.9.3 Programme test

After the input of the programme it is advisable to check that the programme buffer contains the correct data. This is done with the key  in the SHIFT mode.

Pressing the key repeatedly produces the same sequence as during the input of the programme.

9.9.4 Changing the programme data

Select the data line to be changed as in "programme test", SHIFT OFF. This resets the data of the indicated segment. Then the data can be input as usual. Enter the new data

with  each.



9.9.5 Programme start, interruption and abort

It is useful to bring the operating temperature of the thermostat to the programme start temperature T_{start} before starting the programme, or to automatize it by the tolerance range function.



Start the programme sequence with  SHIFT mode. The programme sequence can then be followed by the indication of the setpoint T_s .

L1 shows on the right the segment number, and L2 shows as a setpoint source a P for "programme" on the right.

The keys 1 to 9 are blocked while the programme is running.

The sequence of the programme can be stopped with SHIFT  and then be re-started with SHIFT .

During the interruption of the programme the display shows a W (wait) on the right in L2.

The programme can be aborted with  and then SHIFT  within 2 sec. Afterwards the programme can only be started with segment 1.

9.10 **Connection for analogue signals socket 52 S**

6-pin flange socket according to NAMUR recommendation NE 28.

- Pin 1: voltage output temperature signal channel 2: setpoint T_s , bath temperature T_i , external Pt 100 T_1 or T_2 can be selected. Scaling can be as follows:
0...10 V corresponding to a temperature range selected within the working temperature range (e.g. 50...80°C)
minimum load 4 kOhm
or
0...6 V = -200...400°C = 10 mV/K
0°C = 2 V
or
0...10 V = -100...400°C
or
0...10 V = 0...100°C
- Pin 2: voltage output temperature signal channel 1, other data as pin 1
- Pin 3: ground for all signals
- Pin 4: setpoint voltage input; scaling can be selected as pin 1. $R_i = 12$ kOhm approx.
(+ pin 4; - pin 3)
- Pin 5: current output temperature signal channel 1; signal selection as pin 1. Can be configured for 0...20 mA or 4...20 mA. Scaling can be:
0...20/4...20 mA = -100...400°C
or
0...20/4...20 mA = 0...100°C
or
0...20/4...20 mA = a temperature range selected within the working temperature range (e.g. 50...80°C)
maximum burden 330 Ohm
- Connect only either pin 2 or pin 5!
- Pin 6: setpoint current input; configuration and scaling as pin 5.
Burden 320 Ohm approx. Maximum voltage 15 V!

Connector plug, 6-pin

Cat. No. EQS 057

Use shielded connecting cables. Connect the shielding to the plug case. The mass for all signals (pin 3) must not be connected with ground! If a connection to the ground cannot be avoided use a potential-free signal bridge in between.

Cover the unused connectors with protective caps!

9.11 Analogue inputs

A setpoint in the form of an analogue current or voltage signal can be provided by connection to the socket "Temp.-Signal" 52 S (see Item 9.10).

By pressing the key  in the SHIFT mode the display shows

L1 ANALOGUE INP/OUTP
L2 INP = 0 OFF = 1_

Pressing 0  selects the configuration and scaling of a setpoint input.

The display shows

L1 ANALOG INP. OFF = 0
L2 ON = 1 CONF = 2_

Input 1  switches in a previously configured input as setpoint, and L2 shows at the right end A, indicating that the setpoint is determined by the analogue input. This condition remains stored in case of a fault or after the power is switched off.

Input 0  switches the setpoint back to the setpoint source I internal, i.e. key input.

Scaling takes place interactively by applying the voltage and current values corresponding to the appropriate temperature range limits to the appropriate input.

For pin connections for voltage or current input on socket 52 S see Item 9.10. This method compensates various scaling errors, e.g. also those of the sources connected.

Pressing 2  configures and scales the setpoint input.

The display shows

L1 ANALOG INPUT
L2 U = 0 I = 1

Select a voltage range with 0 . Voltages in the range 0...10.5 V can be handled.

A current range is selected with 1 . Currents in the range 0...22 mA can be handled.

The display shows

L1 ANALOG INPUT
L2 T_{min} = _ . °C

Input the lowest temperature of the range which corresponds to the lowest voltage or current value of the range to be scaled.

Example: range 0...120°C should correspond to 0...10 V approx.

Input 0, 0, 0, 0, 0 .

The display shows



L1 ANALOG INPUT
L2 T_{max} = _ . °C

Input the upper limit of the temperature range with 1, 2, 0, 0, 0 .

If the current input is selected, the programme asks whether 0...20 mA or 4...20 mA is required.

The display shows

L1 CURRENT INPUT
L2 0-20 = 0 4-20 = 1

Select 0  or 1 . This menu item is omitted when the voltage input has been selected.

The display shows

L1 INPUT CAL.?
L2 YES = 1 NO = 0

Here the decision is made whether an automatic calibration procedure is started, or whether the voltage or current values from the last calibration procedure are retained

with input 0 .

The display returns to the standard display.

With a new calibration the voltage or current source (e.g. setpoint unit, programmer) must be connected up. The range limits must be adjustable.

The unit may switch to fault if the input signal is not connected. If this is the case it is

necessary to connect the input signal first. Then press the reset key  and calibrate in the same way as described above.

Select recalibration with 1 .

The display shows

L1 SET U_{min}
L2 YES = 1

When the voltage or current corresponding to the lower range limit is applied to the input, confirm this by input of 1 .

The display shows

L1 -----wait-----
L2 XXXXXXXXXXXXXXXX

The calibration takes approx. 20 sec. The display then shows

L1 SET U_{max}
L2 YES = 1

When the voltage or current corresponding to the upper range limit is applied to the input, confirm this by input of 1 .

The display shows

L1 -----wait-----
L2 XXXXXXXXXXXXXXXX

The calibration takes approx. 60 sec. The display then returns to the standard display. The calibration is finished.

Switch-on the external setpoint from an analogue input as described in Item 9.11.2.

9.12 Analogue outputs

Two analogue output channels are available at the socket "Temp.-Signal" 52 S (see Item 9.10). They can be set to carry the temperature values

Ti	=	bath temperature
T1	=	temperature at ext. Pt 100 T1
T2	=	temperature at ext. Pt 100 T2
TS	=	setpoint

9.12.1 Temperature signal channel 1

Channel 1 can be configured at socket 52 S on pin 2 as voltage output or on pin 5 as current output. Press key  in SHIFT mode.

The display shows

L1 ANALOG INP/OUTP
L2 INP = 0 OUTP = 1

Select the processing of the outputs by pressing 1 . The display shows

L1 Analog outputs
L2 Chan 1=1 Chan 2=2

Select channel 1 by pressing 1 . The display shows

L1 Analog output
L2 U = 0 I = 1_

Select the current output with 1 . The display shows

L1 CURRENT OUTPUT
L2 0-20=0 4-20=1

Select the required current range 0...20 mA or 4...20 mA by pressing 0 or 1 .

The current range selection is omitted if the voltage range 0...10 V has been selected in the previous menu. The display shows the scalings available for selection

L1 CONFIGURABLE=1
 L2 analog output_

By pressing the key  (SHIFT ON) the pre-set scalings are displayed consecutively.

The selection is made by input of the appropriate code (SHIFT OFF).

Configurable means that the temperature range required to correspond to the voltage range 0...10 V, current range 0...20 mA or 4...20 mA can be determined by setting the range start (T_{min}) and the range end (T_{max}).

The display shows

L1 CONFIGURABLE=1
 L2 T_{min} =_ . °C

Example: range 20...220°C

Input 0, 2, 0, 0, 0 . The display shows

L2 T_{max} =_ . °C

Input 2, 2, 0, 0, 0 .

The following fixed scalings are available:

-200...400°C = 0...6 V = 10 mV/K
 0°C = 2 V Code 2

-100...400°C = 0...10 V or 0...20 mA or 4...20 mA Code 3

0...100°C = 0...10 V or 0...20 mA or 4...20 mA Code 4

The display then shows

L2 T_i T₁ T₂ T_s 0-3_

E.g. to set the bath temperature on channel 1 input 0 .

Similarly for the temperature signal of the external Pt 100 T₁ input 1  etc.
 The display then returns to the standard display.

9.12.2 Temperature signal channel 2

Channel 2 is purely a voltage output at socket 52 S on pin 1. The selection is made as described for channel 1 in Item 9.12.1 except that current ranges cannot be selected.

9.13 Safety function

The operation of the safety devices of the units has already been described under Item 4.1.

After starting up the user should confirm the correct operation of the safety devices. If the unit operates without supervision we recommend that this check should be carried out daily.

9.13.1 Low-level cut-out

For a correct operation of the low-level cut-out it is essential that the float switch operates correctly. To check this, lower the level in the bath by draining away some of the liquid. When the bath level falls below the minimum level (approx. 20 mm above the upper heater winding) the pump, the heating and the refrigeration unit switch off on all poles.

The display shows the message

```
L1    LEVEL
L2    TOO LOW
```

and there is a warning beep.

To re-start fill up the bath and press the reset key  twice (with approx. 1 sec interval).

9.13.2 Adjustable overtemperature limiter

To check it the switch-off point TO has to be set below the current bath temperature. Note that an input of TO below the setpoint TS produces the message

```
L2    TS  >>  TO
```

and the previous value for TO is retained.

Therefore the setpoint TS has to be lowered first by a few degrees before carrying out this test.

The overtemperature switch-off point can then be set e.g. 1 K below the current bath temperature.

Example: $T_i = 60^{\circ}\text{C}$
 $T_s = 60^{\circ}\text{C}$
 $T_o = 65^{\circ}\text{C}$

To check the operation of the overtemperature limiter, press  (SHIFT OFF). Input

$T_s = 20^{\circ}\text{C}$, press , the display shows

L1 $T_i = 60.00^{\circ}\text{C C}$
 L2 $T_o : 65.00^{\circ}\text{C Ti I}$

If T_u is shown in L2, press  again!

Now input 0, 5, 8, 0, 0 .

The switch-off point of the overtemperature limiter is now 2 K below the bath temperature T_i .

The display shows the message



L1 TEMPERATURE
 L2 TOO HIGH!

with a beep. Heating and pump are switched off on all poles.

To restart the unit press the reset key .

The display shows the standard display.

Now press  and set T_o to a value above the bath temperature, e.g. 70°C :

Input 0, 7, 0, 0, 0 . Then press the key  once more. The unit returns to normal operation.

Note: The overtemperature switch-off point has to be set at least 25 K below the fire point of the bath liquid used according to EN 61010.

In case of any malfunction under Items 9.13.1 and 9.13.2 the unit must immediately be taken out of use and checked by an engineer, otherwise its safety is no longer ensured.

9.13.3 Connection potential-free contact "Combined fault" 12 N (Alarm off)

3-pin flange connector conforms to NAMUR recommendation NE 28

- 1 = n.o. (make)
- 2 = common
- 3 = n.c. (break)
- 1,2 are linked when unit operation is OK.

Use shielded connecting cables. Connect the shielding to the plug case. Cover the unused connectors with protective caps!

Coupling socket 3-pin

Cat.No. EQD 047

9.14 Serial interface RS 232 C

9-pin sub-D socket 53 S

9.14.1 Data of the RS 232 C interface

Cables used (computer end)

<u>Computer</u>		<u>Thermostat</u>	
25-pin		9-pin	
3	R x D	2	2 T x D (transmitted data)
2	T x D	3	3 R x D (received data)
7	SG	5	5 signal ground
6	DSR	6	6 DTR (data terminal ready)
4	RTS	7	7 CTS (clear to send)
5	CTS	8	8 RTS (request to send)

Use shielded connecting cables. Connect the shielding to the plug case. Cover the unused connectors with protective caps!

Using this interface it is possible to transfer the following data from or to a computer with a suitable interface:

1. Transfer of the setpoint from the computer to the thermostat
2. Read-out of the bath temperature T_i , the external temperature T_1 , the external temperature T_2 and the setpoint on the unit
3. Transfer of the low temperature and overtemperature switch-off point
4. Read-out of the set overtemperature and undertemperature switch-off point
5. Read-out of the fault signal
6. Transfer of the ramp segments and their processing

7. Status signal
8. Read-out of the control parameter and transfer
9. External controller status and start



9.14.2 General principles



The interface operates with two stop bits, no parity bit and with 8 data bits. The transfer rate can be set to 4800 baud or 9600 baud (see Item 9.4.6).



Values from the computer can be transferred directly to the thermostat, i.e. transmitted, e.g. OUT, SEG and START commands, or data can be transmitted from the thermostat to the computer on request with an IN command. An OUT, SEG or START command, if transmitted correctly, is always acknowledged by the thermostat with the message "OK" followed by LF and CR.

This message, like any other response, has to be requested by the computer!

Any output command (OUT, SEG, START, STOP) switches the thermostat to remote operation. This can be recognized by an R (setpoint source RS 232) on the right in L2.

Then all the keys are locked except for the functions "SHIFT " and "SHIFT .

If there is no output instruction from the connected computer the keyboard can be activated until the next output instruction by pressing the keys  .

The data requests by the thermostat (IN commands) only lock the programme keys "SHIFT " and "SHIFT ". All the other key functions are in operation.

In the following text the symbol "_" will be taken to mean blank (no character).

RS 232 interface and controller are operated by a single processor; for optimum control it is therefore advisable to have pauses of at least 100 msec between the interface commands.

9.14.3 Output commands

OUT_XXX.XX Setpoint transfer with up to 3 places before the decimal point and up to 3 places behind. This includes the negative sign.

Transfer can take various forms, e.g. for 5.00°C: 005.00, 05, 05.0, 005, 5.00.

A BASIC programme for the IBM PC which can be used to transfer any values between the set upper limit (see Item 9.3.4) and which displays the response "O.K." or a possible error message, may be as follows:

Note: set baud rate to 4800 (see Item 9.4.5)!

```

10      OPEN "COM1:4800,N,8,2" AS #1
20      CLS
30      LOCATE 8,5:PRINT SPC(70)
40      LOCATE 8,5
50      INPUT "Enter your command (without OUT_)";VALUE$
60      PRINT #1;"OUT_"+VALUE$
70      INPUT #1;A$
80      LOCATE 12,5:PRINT SPC(50)
90      LOCATE 12,5:PRINT "Response of the thermostat";A$
100     TI = TIMER+1
110     IF TI > TIMER THEN 110
120     GOTO 30
130     END
  
```

The following values can be transmitted similarly to the thermostat:

OUT_LXXX.XX	switching point for low temperature (usually set to the lower range limit of the thermostat)
OUT_HXXX.XX	overtemperature switch-off point. For safety reasons it is essential that, after the transfer, this value is read back with the command IN_9 and checked!
OUT_XPXXX.XX	setting of the control parameter X_p for the controller
OUT_TNXXX.XX	setting of the control parameter T_n
OUT_TVXXX.XX	setting of the control parameter T_v
OUT_RT1	switches the control variable to the source external Pt 100 T1 (external control)
OUT_RT2	switches the control variable to the source external Pt 100 T2 (external control)
OUT_RT <i>i</i>	switches the control variable to the source T_i (probe in the bath); control according to the bath temperature.
SEG_XXX.XX_XX:XX	using this programme segment command a segment can be written into the programmer buffer. It indicates the target temperature and the segment time hours (2 digits max.) and minutes (59 max.). The segment start is formed by the current setpoint, i.e. before the transfer of a programme segment it is useful to transfer a setpoint as segment start suitable for the subsequent segment, using OUT_XXX.XX.
"_"	blank (no character)

SEG_(XX)_XXX_XX:XX	single segment with segment number, used when whole temperature programmes are to be loaded from the computer to the thermostat. Thus, in contrast to the command SEG_, several segments may be transmitted. The programme starts with the latest setpoint; therefore please check before START whether the setpoint suitable for the first segment is available in the unit.
OUT_TBX.X	the tolerance range value is ½ of the value of the total range; i.e. 0.5 is 0.5 K; range 0.1...9.9 K. 0.0 switches off the tolerance range function.
OUT_CYXX	number of the programme cycles, range 1...99. 0 switches off the function, i.e. the programme is repeated until it is stopped manually.
START	starts the segment contained in the programme buffer
STOP	stops the programme segment run. With START the programme segment starts again from the beginning.

9.14.4 Requesting data from the thermostat

IN_1	indication of the bath temperature (Ti), i.e. the request of the thermostat to transmit the bath temperature.
IN_2	indication of the temperature at the external probe T1
IN_3	indication of the current setpoint (Ts)
IN_4	status signal, 7 characters
char 1 from the left:	overtemperature fault = 1, no fault = 0
char 2:	low level fault = 1, level OK = 0
char 3:	programmer segment running = 1, programmer segment off = 0
char 4:	control according to the bath temperature (Ti) = 0, T1 = 1, T2 = 2
char 5:	setpoint set by analogue inputs = 1, analogue inputs off = 0
char 6:	indicates whether external Pt 100 T1 is connected = 1, or not connected = 0
char 7:	indicates whether external Pt 100 T2 is connected = 1, or not connected = 0

LAUDA Ultra-Thermostats
UB 20(-D), UB 25, UB 50,
UB 20 F, UB 20 J, UB 30 J, UB 40 J, UB 65 J
UB 20 JL, UB 30 JL, UB 40 JL

IN_5 invalid
IN_6 invalid
IN_7 indication of the temperature of the external probe T2
IN_8 indication of the current low temperature switch-off point TU
IN_9 indication of the current overtemperature switch-off point To
IN_A indication of the current value of Xp
IN_B indication of the current value of Tn
IN_C indication of the current value of Tv

Examples:

A BASIC programme used to transfer values from the thermostat to the computer and to display them specifying the channel number (e.g. 1 for IN_1, i.e. the bath temperature), is as follows:

Note: set baud rate to 4800 (see Item 9.4.5)!

```
10        OPEN "COM1:4800,N,8,2" AS #1
20        CLS
30        LOCATE 8,5:PRINT SPC(20)
40        LOCATE 8,5
50        INPUT "Channel No.:";NO$
60        PRINT #1;"IN_"+NO$
70        INPUT #1;A$
80        LOCATE 12,5:PRINT SPC(50)
90        LOCATE 12,5:PRINT "Response of the thermostat";A$
100       TI = TIMER+1
110       IF TI > TIMER THEN 110
120       GOTO 30
130       END
```

The isolation of the status data may be as follows:

LEFT \$ (A\$,1)	=	overtemperature fault
MID \$ (A\$,2,1)	=	low-level fault
MID \$ (A\$,3,1)	=	programme segment running
MID \$ (A#,4,1)	=	control by Ti, T1 or T2
MID \$ (A\$,5,1)	=	analogue input on/off
MID \$ (A\$,6,1)	=	external Pt 100 T1 connected
RIGHT \$ (A\$,1)	=	external Pt 100 T2 connected

9.14.5 Error messages on the computer

The following error messages can be reported from the thermostat to the computer during operation:

- ERR-2: invalid inputs (e.g.: overflow of the input buffer)
- ERR-3: invalid command
- ERR-5: invalid command when switching the control variable for the controller, e.g. external controller
OUT_RT2. Other command than OUT_RTI, OUT_RT1, OUT_RT2.
- ERR-6: temperature value can not be set
- ERR-7: syntax error in channel number
- ERR-8: channel does not exist

9.15 Timing clock function

The unit is equipped with a clock indicating day, month, year, weekday, hours and minutes and provides these for the timing function.

The clock is backed for approx. 10 years by a built-in battery so that the clock continues to operate even when the unit is not connected to the electrical supply.



9.15.1 Setting and indication of date and time

This function is only required when changing from summer to winter time and vice versa, or when the unit is being operated in other time zones. Date and time are set at the factory when the unit is started up for the first time.

By pressing the key  in the SHIFT mode the display shows

L1 Clock = 0 Activ = 1

L2 SET = 2 FUNCT = 3

By the input of 0  date and time are indicated.  returns to the standard

display. The input of 2  (SET) allows date and time to be altered. The display shows:

L1 DA MO YE H MI

L2 _ . . :

Day, month, year, weekday, hours and minutes are now input in sequence.

Weekday code:



- | | |
|---|-----------|
| 1 | Monday |
| 2 | Tuesday |
| 3 | Wednesday |
| 4 | Thursday |
| 5 | Friday |
| 6 | Saturday |
| 7 | Sunday |

The hours are input from 0 to 24 (factory-set to Central European Time).

Example: L2 19.01.94 3 16:05

Terminate the input with .

9.15.2 Timing clock function

By pressing the key  in SHIFT mode the display shows the menu as described in Item 9.15.1. Select the timing function FUNCT = 3 with 3 .

The display shows



- | | |
|----|-------------------|
| L1 | Thermostat ON = 1 |
| L2 | OR OFF = 0 |

Here it can be selected whether the thermostat should automatically switch on or off at the time to be selected subsequently under Item 9.15.3. Input either 1 or 0 as appropriate.

A display to input date and time appears.

Input here the switching point for the timing function as described under Item 9.15.1 and enter it with . The display returns to the standard display.

9.15.3 Activating the timing clock function

By pressing the key  in SHIFT mode the display shows the selection menu as described in Item 9.15.1. Activate the timing function with ACTIV = 1 by the input of 1 . Again the display shows

- | | |
|----|----------------|
| L1 | Clock |
| L2 | ON = 1 OFF = 0 |

Normally 1  is input here to activate the timing function.

The timing clock symbol now appears in line L1 before the last position. If the previous selection was that the thermostat should switch on automatically, the thermostat now switches off and starts up at the selected time.

When the unit has been switched off through the timing function, the display shows

L2 CLOCK STOP!

The activated timing function can always be switched off with off = 0, i.e. with 0 .

In addition the timing function can be cancelled at any time with .

10 **Maintenance**

10.1 ***Safety notes in case of repairs***



Always pull out the mains plug for all repair and cleaning operations! Repairs on the units with the cover removed must only be carried out by a qualified electrician.

10.2 ***Repair and re-initialisation***

LAUDA thermostats are largely free from maintenance. Dirty thermostatic liquid should be removed through the drain cock and replaced. If the unit should become faulty it may be advisable to return only the faulty module where appropriate.

For reasons of safety and keeping to the EMC Guideline only original cables must be used.





When replacing the control unit (electronics), check whether the new control unit has been programmed for the correct basic unit type. If the correct type (R 400 P) does not appear after having switched on the mains switch, proceed as follows:

Mains switch off, press the keys  and  simultaneously, and at the same time switch on the supply.

Wait until the following display appears:

L1 RK 20 K = 0 K 12 K = 1

L2 Type

Release the keys  and , and go through the menu with the key  until the required type appears. Input the code number and enter with .

The type designations are shown abbreviated.

The unit is protected with a fuse 6.3 x 32 FF16A (at the rear of R 400 P). The control circuit of the unit has a separate fuse; a fuse 5 x 20 F4A is located in the control unit. This is accessible after removing the cover. When the fuse has blown the green lamp in the mains switch does not light up.

10.3 **Cleaning**

The unit can be cleaned using a cloth moistened with water with the addition of a few drops of (domestic) detergent. No water must find its way into the control unit.

The user is responsible for any necessary decontamination if dangerous materials have been spilled on or inside the unit. This applies in particular if the unit is removed for a different use, for repair, storage etc.

The method of cleaning or decontamination is determined by the expertise of the user. If the user has any doubts on whether this may damage the unit he has to contact the manufacturer.

10.4 **Spares ordering**

When ordering spares please specify the equipment type and number on the label. This avoids queries and prevents the supply of the wrong goods!

We shall always be happy to deal with queries, suggestions and complaints.

LAUDA DR. R. WOBSE
GMBH & CO. KG
Postfach 1251
97912 Lauda-Königshofen
Tel: (+49) (0) 9343/ 503-0
Fax: (+49) (0) 9343/ 503-222
E-mail [info @ lauda.de](mailto:info@lauda.de)
Internet <http://www.lauda.de>

11 Accessories

LAUDA Thermostats (circular, of normal height)

Stainless steel plating racks

Test tube rack for 20 pieces up to 16 mm dia.
for U 6, U 6-D Cat. No. UG 004

Pycnometer rack for 4 pieces
for U 6, U 6-D Cat. No. UG 005

Test tube rack for 48 pieces up to 16 mm dia.
for U 12, U 12-D Cat. No. UG 006

Pycnometer rack for 12 pieces
for U 12, U 12-D Cat. No. UG 007

Test tube rack for 20 pieces up to 16 mm dia.
for US 6, US 6-D Cat. No. UG 004

Pycnometer rack for 4 pieces
for US 6, US 6-D Cat. No. UG 005

Test tube rack for 48 pieces up to 16 mm dia.
for US 12, US 12-D Cat. No. UG 006

Pycnometer rack for 12 pieces
for US 12, US 12-D Cat. No. UG 007

Test and centrifugal tubes etc.
UB 20(-D) up to 2 pieces, UB 25 up to 4 pieces, UB 50 up to 8 pieces

RH 13	for 56 tubes 10 - 13 dia., 80 mm immersion	Cat. No. UG 086
RH 18/1	for 36 tubes 14 - 18 dia., 80 mm immersion	Cat. No. UG 087
RH 18/2	for 36 tubes 14 - 18 dia., 110 mm immersion	Cat. No. UG 088
RH 30	for 10 tubes 24 - 30 dia., 110 mm immersion	Cat. No. UG 089

Rising platform with continuous height adjustment
for UB 20(-D); bench area 240 x 225 mm;
When the Rising platform is mounted the bath opening
will be reduced to 250 x 225 mm. Cat. No. LTZ 012

Cover plate UB 20(-D),
1 opening 195 mm dia. ,
1 set water bath rings, 1 rising platform Cat. No. LTZ 011

Cover plate UB 25/2
2 openings 195 mm dia., 2 sets water bath rings,
2 rising platforms, 1 stand rod Cat. No. LTZ 013

LAUDA Ultra-Thermostats
UB 20(-D), UB 25, UB 50,
UB 20 F, UB 20 J, UB 30 J, UB 40 J, UB 65 J
UB 20 JL, UB 30 JL, UB 40 JL

Cover plate UB 25/4
4 openings 100 mm dia., 4 sets water bath rings,
4 rising platforms, 4 stand rods
Cat. No. LTZ 014

Cover plate UB 50/4
4 openings 195 mm dia., 4 sets water bath rings,
4 rising platforms, 4 stand rods
Cat. No. LTZ 015

Cover plate UB 50/8
8 openings 100 mm dia., 8 sets water bath rings,
8 rising platforms, 8 stand rods
Cat. No. LTZ 016

Rising platform or cover plate with rising platform for UB 30 or UB 40 on request.

LAUDA Through-Flow Chillers

for cooling thermostats, in particular	DLK 10	Cat. No. LFD 105
at operating temperatures below	DLK 25	Cat. No. LFD 106
the working temperature range	DLK 45	Cat. No. LFD 107

LAUDA Pt 100 platinum resistance thermometers
to DIN IEC 751 Class A for external control
and other temperature measurement

Pt 100-42

all-glass version with NS 14/23 ground taper DIN 12242
Temp. range -100...300°C
50% response time 0.8 sec
Overall length approx. 115 mm
4-wire circuit
Fig. 1
Cat. No. ETP 049

Pt 100-44

all-glass version with NS 14/23 ground taper DIN 12242
Temp. range -100...300°C
50% response time 0.8 sec
Overall length approx. 320 mm
Fig. 2
Cat. No. ETP 007

Pt 100-66

as Pt 100-44
Overall length approx. 430 mm
Fig. 2
Cat. No. ETP 008

Pt 100-90

stainless steel protection tube 4 mm dia.
Temp. range -100...300°C
50% response time 1.5 sec
Overall length approx. 120 mm
4-wire circuit
Fig. 3
Cat. No. ETP 050

LAUDA Ultra-Thermostats
UB 20(-D), UB 25, UB 50,
UB 20 F, UB 20 J, UB 30 J, UB 40 J, UB 65 J
UB 20 JL, UB 30 JL, UB 40 JL

Pt 100-70

stainless steel protection tube 4 mm dia.
Temp. range -200...300°C
50% response time 1.5 sec
Overall length approx. 290 mm
4-wire circuit
Fig. 3

Cat. No. ETP 009

Pt 100-92

stainless steel protection tube 4 mm dia.
with attached Silicone cable 2 m long and plug
Temp. range -100...200°C
50% response time 3 sec
Overall length approx. 250 mm
4-wire circuit
Fig. 4

Cat. No. ETP 051

Connecting cable

with 4-pin plug for external control on
all C-and K-units and for
digital thermometer for Pt 100-44 and
Pt 100-66 1.5 m
length as specified

Cat. No. UK 048

Cat. No. UK 213

for Pt 100-42, Pt 100-70, Pt 100-90 1.5 m
length as specified

Cat. No. UK 047

Cat. No. UK 212

Screw clamp fitting

stainless steel, with Teflon pressure ring
for Pt 100 resistance thermometer 4 mm dia.
Fig 5

Cat. No. HX 078

LAUDA Ultra-Thermostats
 UB 20(-D), UB 25, UB 50,
 UB 20 F, UB 20 J, UB 30 J, UB 40 J, UB 65 J
 UB 20 JL, UB 30 JL, UB 40 JL

Figure 1

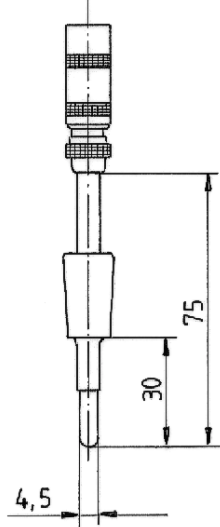

Pt 100-42

Figure 2

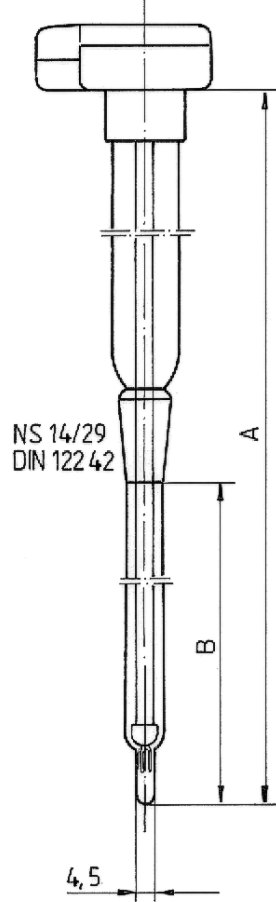

	A	B
Pt 100-44	300	135
Pt 100-66	410	245

Figure 3

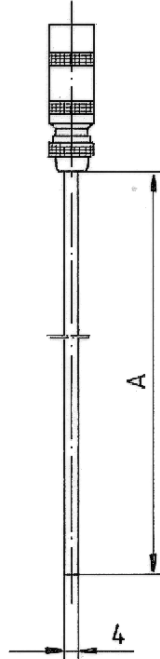

	A
Pt 100-90	80
Pt 100-70	250

Figure 4

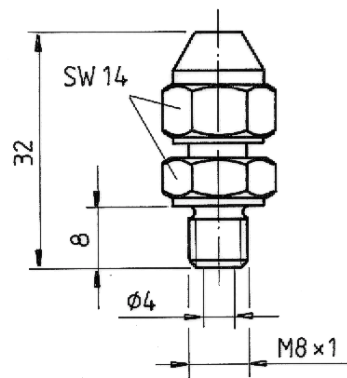
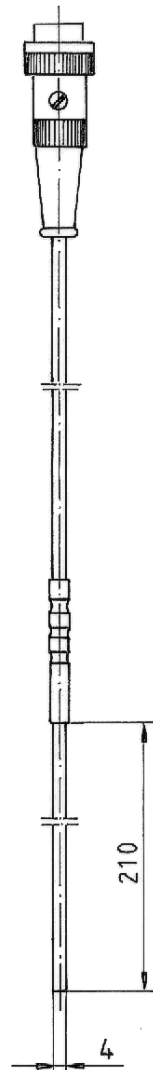
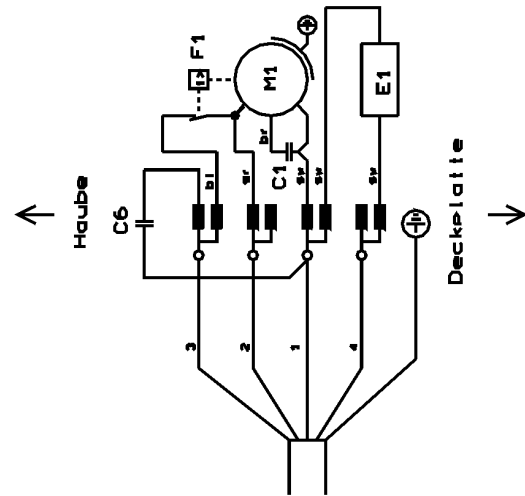
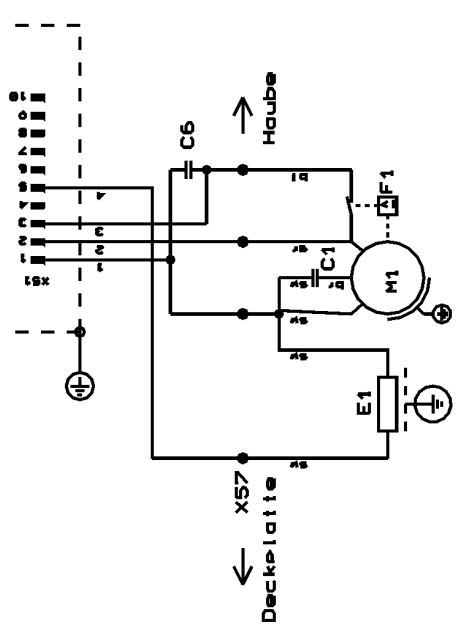
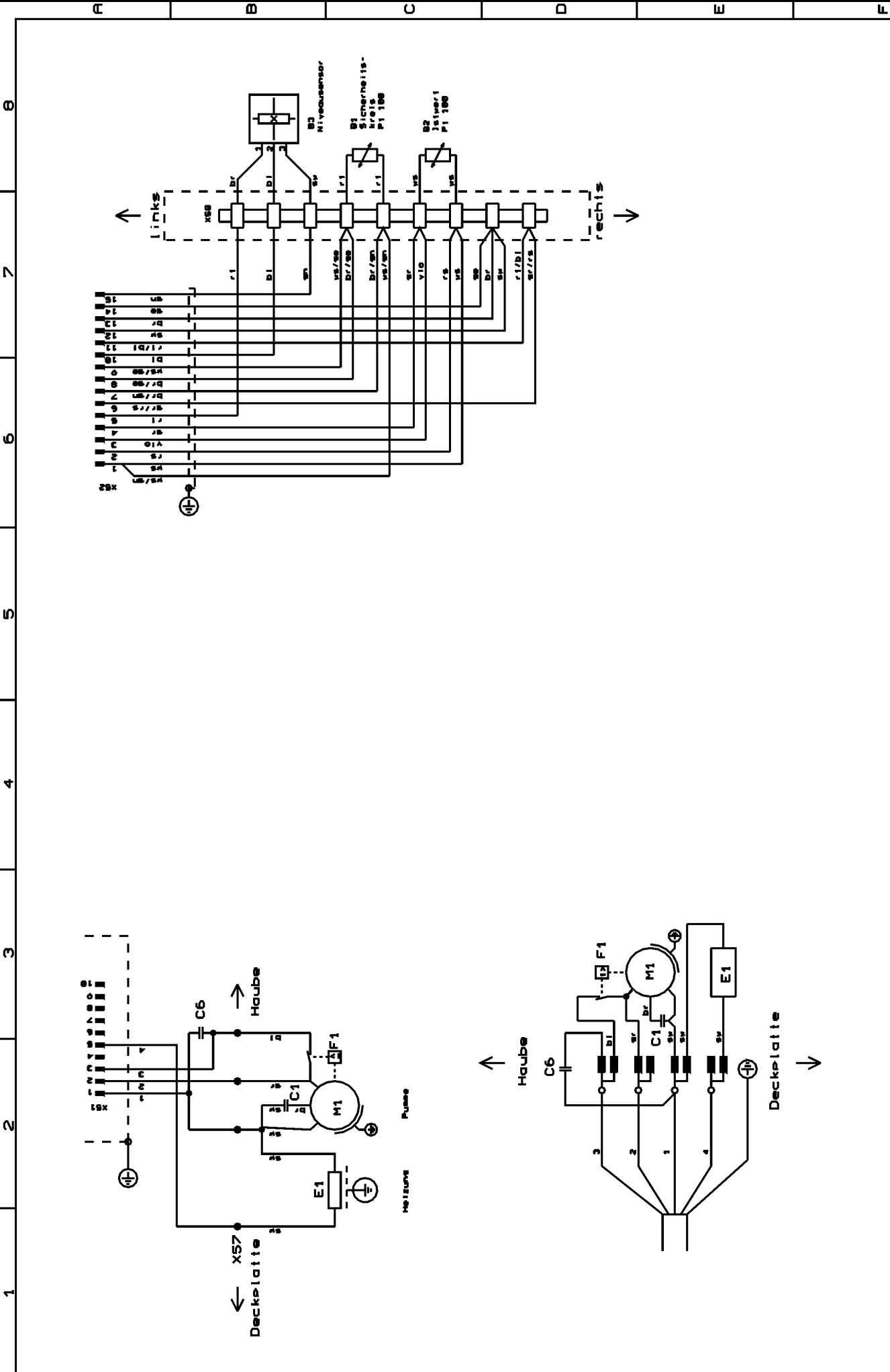

Figure 5

Für diese Zeichnung behalten wir uns alle nicht ausdrücklich eingeräumten Nutzungsrechte einschließlich der Vervielfältigung und Weitergabe an Dritte vor. Technische Änderungen vorbehalten



UB X, UB x F, UB x J, UB x JL		UB X, UB x F, UB x J, UB x JL		UB X, UB x F, UB x J, UB x JL		UB X, UB x F, UB x J, UB x JL		UB X, UB x F, UB x J, UB x JL		UB X, UB x F, UB x J, UB x JL	
Blatt 2		Blatt 2		Blatt 2		Blatt 2		Blatt 2		Blatt 2	
2 Bl.		2 Bl.		2 Bl.		2 Bl.		2 Bl.		2 Bl.	
07.03.1		07.03.1		07.03.1		07.03.1		07.03.1		07.03.1	
Schaltplan		Schéma de connexions		Circuit diagram		Circuit diagram		Circuit diagram		Circuit diagram	
LAUDA		Dr. R. Maber GmbH & Co KG		E.R.S.G		E.R.S.G		E.R.S.G		E.R.S.G	
Datum		11.01.1996		Urger.		Urger.		Urger.		Urger.	
Bearb.		B. Schmitz		E.R.S.G		E.R.S.G		E.R.S.G		E.R.S.G	
Datum				E.R.S.G		E.R.S.G		E.R.S.G		E.R.S.G	
Name				E.R.S.G		E.R.S.G		E.R.S.G		E.R.S.G	
Titel				E.R.S.G		E.R.S.G		E.R.S.G		E.R.S.G	
Zusl. Änderungen				E.R.S.G		E.R.S.G		E.R.S.G		E.R.S.G	

Geräteliste Schaltplan
List of parts circuit diagram
Liste de schéma connexions
230V; 50Hz

UB 20, UB 20 J,
UB 20 F, UB 20 JL
UB 25, UB 50
UB 30, UB 30 J,
UB 30 JL
UB 40, UB 40 J,
UB 40 JL,
UB 65 J

gültig ab Serie Z 01
at serial no.
à partir

Teil-Nr. Part No. Pièce no.	Bezeichnung	Designation	Désignation	Bestell-Nr. Ref.-No. No.Ref UB 20 F	Bestell-Nr. Ref.-No. No.Ref UB 30, UB 30 J, UB 40, UB 40 J, UB 65 J	Bestell-Nr. Ref.-No. No.Ref UB 20, UB 20 J, UB 25, UB 50
B 1	Pt 100 Fühler Sicherheitskreis	Pt 100 Probe Safety circuit	Pt 100 Sonde Circuit sécurité	ETP 046	ETP 048	ETP 046
B 2	Pt 100 Fühler Regelung	Pt 100 Probe Controller	Pt 100 Sonde Réglage	ETP 046	ETP 048	ETP 046
B 3	Niveausensor	Level sensor	Niveau sensor	EKS 034	EKS 034	EKS 034
C 1	Motorkondensator	Motor condenser	Condensateur moteur	ECA 004	ECA 004	ECA 004
C 6	Entstörkondensator	Interference Capacitor	Condensateur d'antiparissage	ECF 003	ECF 003	ECF 003
E 1	Heizkörper	Heater	Corps de chauffe	UH 121	UH 124	UH 125
F 1	Übertemperaturschutz (Umwälzpumpe)	Overtemperature protection (Circulating pump)	Protection de surpression (Pompe de circulation)	Intern	Intern	Intern
M 1	Motor	Motor	Moteur	EM 047	EM 058	EM 047
X 51	Steckereinsatz 10 pol.	Connector insert	Insert du connecteur	EQS 031+ EQG 016	EQS 031+ EQG 016	EQS 031+ EQG 016
X 52	Steckerleiste SUB-D 15pol.	Socket terminal strip	Réglette à fiches mâles	EQM 080+ EQG 027	EQM 080+ EQG 027	EQM 080+ EQG 027
X 57	Klemmleiste	Line up terminal	Barrette à bornes	EZK 071	EZK 071	EZK 071
X 58	Lötleiste	Terminal strip	Plot de brasage	EZK 019	EZK 019	EZK 019

Für diese Zeichnung behalten wir uns alle nicht ausdrücklich eingeräumten Nutzungsrechte einschließlich der Vervielfältigung und Weitergabe an Dritte vor. Technische Änderungen vorbehalten

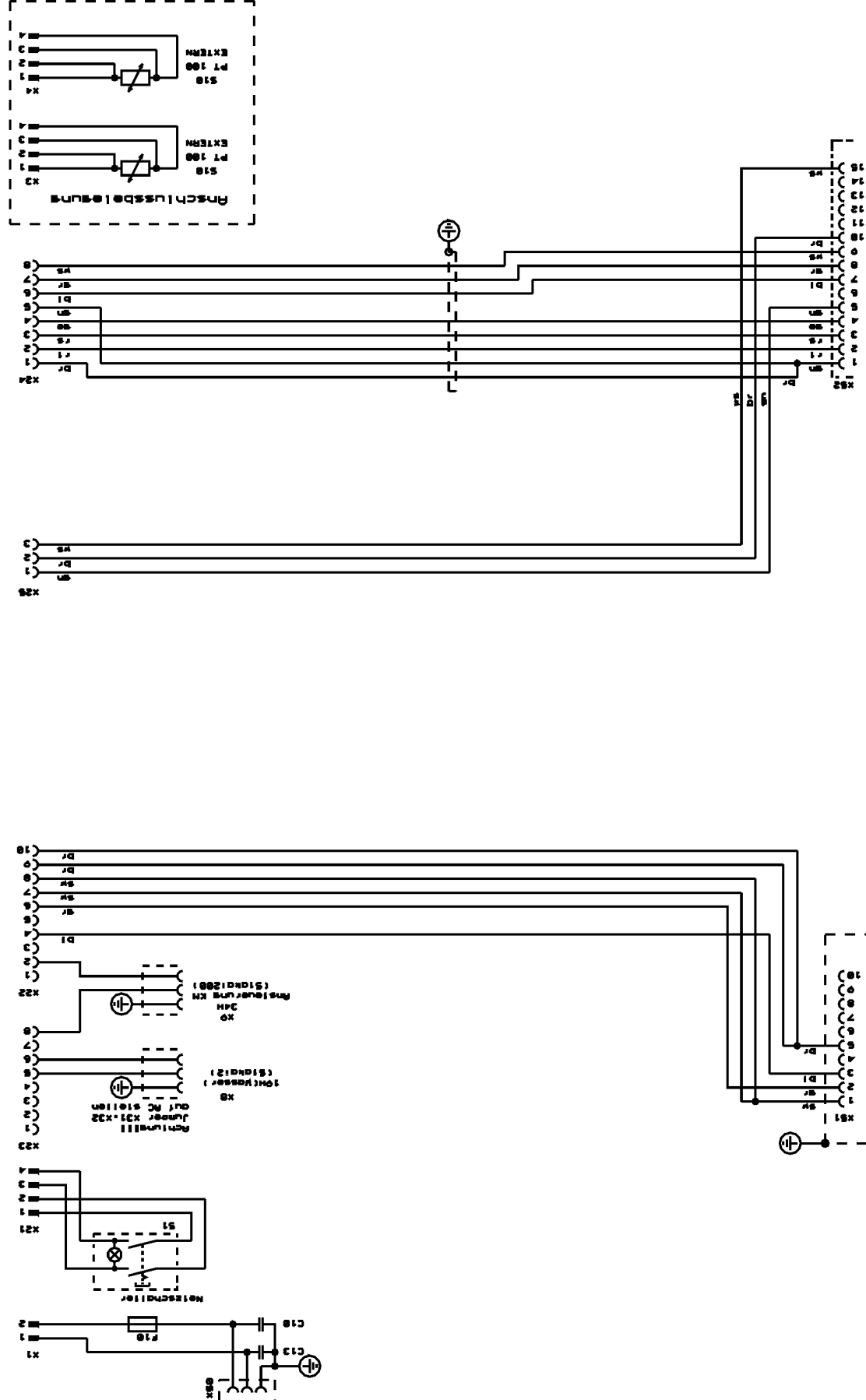

ab Serie X01001 (UY122 Version 2.14)

Datum		11.01.1995		Urspr.		Ers.f		Ers.g		Ers.h		Ers.i		Ers.j		Ers.k		Ers.l		Ers.m		Ers.n		Ers.o		Ers.p		Ers.q		Ers.r		Ers.s		Ers.t		Ers.u		Ers.v		Ers.w		Ers.x		Ers.y		Ers.z			
Bearb.		B. Schmitz		Name		Ers.f		Ers.g		Ers.h		Ers.i		Ers.j		Ers.k		Ers.l		Ers.m		Ers.n		Ers.o		Ers.p		Ers.q		Ers.r		Ers.s		Ers.t		Ers.u		Ers.v		Ers.w		Ers.x		Ers.y		Ers.z			
a		10.12.98		Name		Ers.f		Ers.g		Ers.h		Ers.i		Ers.j		Ers.k		Ers.l		Ers.m		Ers.n		Ers.o		Ers.p		Ers.q		Ers.r		Ers.s		Ers.t		Ers.u		Ers.v		Ers.w		Ers.x		Ers.y		Ers.z			
Zust.		Anspr.		Tsch		Name		Ers.f		Ers.g		Ers.h		Ers.i		Ers.j		Ers.k		Ers.l		Ers.m		Ers.n		Ers.o		Ers.p		Ers.q		Ers.r		Ers.s		Ers.t		Ers.u		Ers.v		Ers.w		Ers.x		Ers.y		Ers.z	
Zust.		Anspr.		Tsch		Name		Ers.f		Ers.g		Ers.h		Ers.i		Ers.j		Ers.k		Ers.l		Ers.m		Ers.n		Ers.o		Ers.p		Ers.q		Ers.r		Ers.s		Ers.t		Ers.u		Ers.v		Ers.w		Ers.x		Ers.y		Ers.z	
Zust.		Anspr.		Tsch		Name		Ers.f		Ers.g		Ers.h		Ers.i		Ers.j		Ers.k		Ers.l		Ers.m		Ers.n		Ers.o		Ers.p		Ers.q		Ers.r		Ers.s		Ers.t		Ers.u		Ers.v		Ers.w		Ers.x		Ers.y		Ers.z	
Zust.		Anspr.		Tsch		Name		Ers.f		Ers.g		Ers.h		Ers.i		Ers.j		Ers.k		Ers.l		Ers.m		Ers.n		Ers.o		Ers.p		Ers.q		Ers.r		Ers.s		Ers.t		Ers.u		Ers.v		Ers.w		Ers.x		Ers.y		Ers.z	
Zust.		Anspr.		Tsch		Name		Ers.f		Ers.g		Ers.h		Ers.i		Ers.j		Ers.k		Ers.l		Ers.m		Ers.n		Ers.o		Ers.p		Ers.q		Ers.r		Ers.s		Ers.t		Ers.u		Ers.v		Ers.w		Ers.x		Ers.y		Ers.z	
Zust.		Anspr.		Tsch		Name		Ers.f		Ers.g		Ers.h		Ers.i		Ers.j		Ers.k		Ers.l		Ers.m		Ers.n		Ers.o		Ers.p		Ers.q		Ers.r		Ers.s		Ers.t		Ers.u		Ers.v		Ers.w		Ers.x		Ers.y		Ers.z	
Zust.		Anspr.		Tsch		Name		Ers.f		Ers.g		Ers.h		Ers.i		Ers.j		Ers.k		Ers.l		Ers.m		Ers.n		Ers.o		Ers.p		Ers.q		Ers.r		Ers.s		Ers.t		Ers.u		Ers.v		Ers.w		Ers.x		Ers.y		Ers.z	
Zust.		Anspr.		Tsch		Name		Ers.f		Ers.g		Ers.h		Ers.i		Ers.j		Ers.k		Ers.l		Ers.m		Ers.n		Ers.o		Ers.p		Ers.q		Ers.r		Ers.s		Ers.t		Ers.u		Ers.v		Ers.w		Ers.x		Ers.y		Ers.z	
Zust.		Anspr.		Tsch		Name		Ers.f		Ers.g		Ers.h		Ers.i		Ers.j		Ers.k		Ers.l		Ers.m		Ers.n		Ers.o		Ers.p		Ers.q		Ers.r		Ers.s		Ers.t		Ers.u		Ers.v		Ers.w		Ers.x		Ers.y		Ers.z	
Zust.		Anspr.		Tsch		Name		Ers.f		Ers.g		Ers.h		Ers.i		Ers.j		Ers.k		Ers.l		Ers.m		Ers.n		Ers.o		Ers.p		Ers.q		Ers.r		Ers.s		Ers.t		Ers.u		Ers.v		Ers.w		Ers.x		Ers.y		Ers.z	
Zust.		Anspr.		Tsch		Name		Ers.f		Ers.g		Ers.h		Ers.i		Ers.j		Ers.k		Ers.l		Ers.m		Ers.n		Ers.o		Ers.p		Ers.q		Ers.r		Ers.s		Ers.t		Ers.u		Ers.v		Ers.w		Ers.x		Ers.y		Ers.z	
Zust.		Anspr.		Tsch		Name		Ers.f		Ers.g		Ers.h		Ers.i		Ers.j		Ers.k		Ers.l		Ers.m		Ers.n		Ers.o		Ers.p		Ers.q		Ers.r		Ers.s		Ers.t		Ers.u		Ers.v		Ers.w		Ers.x		Ers.y		Ers.z	
Zust.		Anspr.		Tsch		Name		Ers.f		Ers.g		Ers.h		Ers.i		Ers.j		Ers.k		Ers.l		Ers.m		Ers.n		Ers.o		Ers.p		Ers.q		Ers.r		Ers.s		Ers.t		Ers.u		Ers.v		Ers.w		Ers.x		Ers.y		Ers.z	
Zust.		Anspr.		Tsch		Name		Ers.f		Ers.g		Ers.h		Ers.i		Ers.j		Ers.k		Ers.l		Ers.m		Ers.n		Ers.o		Ers.p		Ers.q		Ers.r		Ers.s		Ers.t		Ers.u		Ers.v		Ers.w		Ers.x		Ers.y		Ers.z	
Zust.		Anspr.		Tsch		Name		Ers.f		Ers.g		Ers.h		Ers.i		Ers.j		Ers.k		Ers.l		Ers.m		Ers.n		Ers.o		Ers.p		Ers.q		Ers.r		Ers.s		Ers.t		Ers.u		Ers.v		Ers.w		Ers.x		Ers.y		Ers.z	
Zust.		Anspr.		Tsch		Name		Ers.f		Ers.g		Ers.h		Ers.i		Ers.j		Ers.k		Ers.l		Ers.m		Ers.n		Ers.o		Ers.p		Ers.q		Ers.r		Ers.s		Ers.t		Ers.u		Ers.v		Ers.w		Ers.x		Ers.y		Ers.z	
Zust.		Anspr.		Tsch		Name		Ers.f		Ers.g		Ers.h		Ers.i		Ers.j		Ers.k		Ers.l		Ers.m		Ers.n		Ers.o		Ers.p		Ers.q		Ers.r		Ers.s		Ers.t		Ers.u		Ers.v		Ers.w		Ers.x		Ers.y		Ers.z	
Zust.		Anspr.		Tsch		Name		Ers.f		Ers.g		Ers.h		Ers.i		Ers.j		Ers.k		Ers.l		Ers.m		Ers.n		Ers.o		Ers.p		Ers.q		Ers.r		Ers.s		Ers.t		Ers.u		Ers.v		Ers.w		Ers.x		Ers.y		Ers.z	
Zust.		Anspr.		Tsch		Name		Ers.f		Ers.g		Ers.h		Ers.i		Ers.j		Ers.k		Ers.l		Ers.m		Ers.n		Ers.o		Ers.p		Ers.q		Ers.r		Ers.s		Ers.t		Ers.u		Ers.v		Ers.w		Ers.x		Ers.y		Ers.z	
Zust.		Anspr.		Tsch		Name		Ers.f		Ers.g		Ers.h		Ers.i		Ers.j		Ers.k		Ers.l		Ers.m		Ers.n		Ers.o		Ers.p		Ers.q		Ers.r		Ers.s		Ers.t		Ers.u		Ers.v		Ers.w		Ers.x		Ers.y		Ers.z	
Zust.		Anspr.		Tsch		Name		Ers.f		Ers.g		Ers.h		Ers.i		Ers.j		Ers.k		Ers.l		Ers.m		Ers.n		Ers.o		Ers.p		Ers.q		Ers.r		Ers.s		Ers.t		Ers.u		Ers.v		Ers.w		Ers.x		Ers.y		Ers.z	
Zust.		Anspr.		Tsch		Name		Ers.f		Ers.g		Ers.h		Ers.i		Ers.j		Ers.k		Ers.l		Ers.m		Ers.n		Ers.o		Ers.p		Ers.q		Ers.r		Ers.s		Ers.t		Ers.u		Ers.v		Ers.w		Ers.x		Ers.y		Ers.z	
Zust.		Anspr.		Tsch		Name		Ers.f		Ers.g		Ers.h		Ers.i		Ers.j		Ers.k		Ers.l		Ers.m		Ers.n		Ers.o		Ers.p		Ers.q		Ers.r		Ers.s		Ers.t		Ers.u		Ers.v		Ers.w		Ers.x		Ers.y		Ers.z	
Zust.		Anspr.		Tsch		Name		Ers.f		Ers.g		Ers.h		Ers.i		Ers.j		Ers.k		Ers.l		Ers.m		Ers.n		Ers.o		Ers.p		Ers.q		Ers.r		Ers.s		Ers.t		Ers.u		Ers.v		Ers.w		Ers.x		Ers.y		Ers.z	
Zust.		Anspr.		Tsch		Name		Ers.f		Ers.g		Ers.h		Ers.i		Ers.j		Ers.k		Ers.l		Ers.m		Ers.n		Ers.o		Ers.p		Ers.q		Ers.r		Ers.s		Ers.t		Ers.u		Ers.v		Ers.w		Ers.x		Ers.y		Ers.z	
Zust.		Anspr.		Tsch		Name		Ers.f		Ers.g		Ers.h		Ers.i		Ers.j		Ers.k		Ers.l		Ers.m		Ers.n		Ers.o		Ers.p		Ers.q		Ers.r		Ers.s		Ers.t		Ers.u		Ers.v		Ers.w		Ers.x		Ers.y		Ers.z	
Zust.		Anspr.		Tsch		Name		Ers.f		Ers.g		Ers.h		Ers.i		Ers.j		Ers.k		Ers.l		Ers.m		Ers.n		Ers.o		Ers.p		Ers.q		Ers.r		Ers.s		Ers.t		Ers.u		Ers.v		Ers.w		Ers.x		Ers.y		Ers.z	
Zust.		Anspr.		Tsch		Name		Ers.f		Ers.g		Ers.h		Ers.i		Ers.j		Ers.k		Ers.l		Ers.m		Ers.n		Ers.o		Ers.p		Ers.q		Ers.r		Ers.s		Ers.t		Ers.u		Ers.v		Ers.w		Ers.x		Ers.y		Ers.z	
Zust.		Anspr.		Tsch		Name		Ers.f		Ers.g		Ers.h		Ers.i		Ers.j		Ers.k		Ers.l		Ers.m		Ers.n		Ers.o		Ers.p		Ers.q		Ers.r		Ers.s		Ers.t		Ers.u		Ers.v		Ers.w		Ers.x		Ers.y		Ers.z	
Zust.		Anspr.		Tsch		Name		Ers.f		Ers.g		Ers.h		Ers.i		Ers.j		Ers.k		Ers.l		Ers.m		Ers.n		Ers.o		Ers.p		Ers.q		Ers.r		Ers.s		Ers.t		Ers.u		Ers.v		Ers.w		Ers.x		Ers.y		Ers.z	
Zust.		Anspr.		Tsch		Name		Ers.f		Ers.g		Ers.h		Ers.i		Ers.j		Ers.k		Ers																													

Teil-Nr. Part No. Pièce no.	Bezeichnung	Designation	Désignation	Bestell-Nr. Ref.-No. No.Ref
A 1	Leiterplatte „MP Netz“	Printed circuit board „MP-Mains“	Circuit imprimé „MP-Secteur“	UL 382-1C
A 2	Leiterplatte „CPU“	Printed circuit board „CPU“	Circuit imprimé „CPU“	UL 382-1C
A 3	Leiterplatte „Anzeige Tastatur“	Printed circuit board „Indication Keyboard“	Circuit imprimé „Affichage Clavier“	UL 384-1B
A 4	Leiterplatte „Analog Ausgang“	Printed circuit board „Analog exit“	Circuit imprimé „Sortie analogue“	UL 385-1
A 5	Leiterplatte „Anzeige Display“	Printed circuit board „Indication Display“	Circuit imprimé „Affichage Display“	EAO 091
B 1	Pt 500 Fühler Regelung	Pt 500 Probe control	Pt 500 sonde contrôle	ETP 021
B 2	Schwimmer	Float	Flotteur	US 053
B 6	Pt 500 Fühler Übertemperatur	Pt 500 Probe overtemperature	Pt 500 sonde surtemperature	ETP 021
C 10,C 13	Kondensator	Condenser	Condensateur	ECF 023
F 10	Steuersicherung	Control fuse	Fusible commande	EES 003
	Sicherungshalter	Fuse holder	Porte-fusible	EEH 009
S 1	Netzschalter	Mains switch	Interrupteur secteur	EST 032
X 8	Anschlußbuchse Kühlen	Connection socket Cooling	Douille de jonction Réfrigérissement	EQK 044 + EQZ 006
X 9	Anschlußbuchse Rücklaufsicherung	Connection socket Reflow security valve	Douille de jonction Protection de refoulement	EQD 037 + EQZ 006
X 22	Steckleiste 10 pol.	Socket terminal strip	Réglette à fiches	EZK 056
X 23	Steckleiste 8 pol.	Socket terminal strip	Réglette à fiches	EZK 057
X 24	Buchsenleiste 8 pol.	Socket terminal strip	Réglette à fiches	EQG 025
X 25	Buchsenleiste 3 pol.	Socket terminal strip	Réglette à fiches	EQG 024
X 50	Netzanschluss	Mains connection	Connection secteur	EQD 030
X 51	Steckdoseneinsatz 10pol.	Socket insert	Insert de prise	EQD 026 + EQG 019
X 52	Buchsenleiste SUB-D 15pol.	Socket terminal strip	Réglette à douille	EQF 076

Notes for trouble-shooting for LAUDA Thermostats with P - electronics

LAUDA

Each repair requiring the opening of the control part by means of tools and each work at the electronic part may only be done by a trained technician !

Malfunction	Fault	Reason	Remedy
Green signal lamp of mains switch not alight	Control fuse has actuated		Replace fuse on PCB "MP Mains" 5 x 20; F4A
		Overload on PCB	Replace PCB "MP Mains"
Display: "Level too low"	Bath level too low	Evaporation; external consuming device not refilled	Fill in bath liquid; press reset button twice
		Leakage in hose connections	Check hoses and their connection; if necessary replace them; fill in bath liquid; press reset button twice
	Level detector		Check level detector, plugs and hall sensors; if necessary replace them; check their function carefully For USH 400(/6) fill in bath liquid up to the level mark
Display: "Temperature too high"	Temperature probe	Temperature difference between two probes > 15°C	Replace bath temperature probe (double Pt 100). For USH 400(/6) please check both single Pt 100.
	Temperature of bath liquid above over-temperature switch-off point (To)	Overtemperature switch-off point (To) set too low	Press reset button; adjust overtemp. switch-off point (To) at an higher value; press reset button
		Triac or triggering	Replace triac or PCB "MP Mains"
Display: "External fault"	Contact input 14 N "Fault" is used	Pins ½ not connected	Reason for malfunction caused by external system
		No signal transmitter connected to socket 14 N, though selection at PAR level is activated	Switch off function "Contact input Fault" at PAR level; see operating instructions
Display: "Ts > To"	Wrong inputs	Setpoint adjusted above overtemperature switch-off point (To)	Adjust overtemperature switch-off point (To) at an higher temperature; pay attention to bath liquid, flash point etc. !!
		Overtemperature switch-off point adjusted below setpoint (Ts)	First adjust setpoint (Ts) at a lower value then set requested overtemperature switch-off point
Display: "Ts < Tu"	Wrong input	Setpoint adjusted below low-temperature switch-off point (Tu)	Adjust low-temperature switch-off point (Tu) at a lower value
		Low-temperature switch-off point adjusted above setpoint (Ts)	First adjust setpoint at an higher temperature then set requested low-temperature switch-off point (Tu)

Malfunction	Fault	Reason	Remedy
Setpoint Ts is not adjustable but will disappear	Operating error	Setpoint is determined by the analogue input; see right side of display L2: A	Switch off analogue input
Sound signal appears when a button is pressed		Another function blocks the keyboard e.g.: programme runs; RS 232 active; Parameter etc.	Leave the function or press ESC (RS 232) (R appears on the right side of display L2); Stop access and press the button "Local"
Display: "Tu – Cursor flashes" acoustic signal switches compressor off after 1 min.	Wrong input	Actual value is \leq Tu, resp. setpoint adjusted too close to low-temperature switch-off point Tu; bath temperature (Ti) falls below Tu	Set low-temperature switch-off point (Tu) at a lower value
Display "Out of range"	Wrong input	Tried to enter values being out of admissible ranges; Ts, To, Tu being out of operating temp.	Choose the right values taking into consideration their limitations; check bath liquid or configuration after having switched on the unit
		Programme input out of operating temperature range of the unit	Enter admissible values
		Value for Xp, Tn, Tv above 199,9	Enter admissible values
Tu or To is not adjustable; "Out of range "		Input values are outside of temperature limits of the type of unit or initialization does not fit to the type of unit	Reinitialize type of unit: (see operating instructions "Maintenance"); may also return Default-values
Display: "TA" (only for USH 400(/6)		Motor chamber temperature > 55 °C	Surrounding temperature of the part of the thermostat may be too high (see operating instructions 5.2.8)
Display: ↓ (only for USH 400(/6) RUL and RUK)		Level too low	Fill in bath liquid ; (see operating instructions 5.2.3)
Display: ↑ (only for USH 400(/6) RUL and RUK)		Level in the vessel is close to overflow; heater switches off	Either reduce the amount of thermal liquid or install an other vessel Attention: HOT !!!
Display: "Upper limitation of oil > limitation of unit" (cancelled beginning with software version 1.06)		Admissible working temperature range of bath liquid exceeds operating temperature range of the unit	Bath liquid is accepted, no other steps necessary; unit limitations valid
Setpoint cannot be selected by means of keyboard		Check setpoint selection; see right side of display L2; P=Programme; A=Analogue; R=RS 232	Switch setpoint selection to I=Internal
Display: "External fault – clock stop!"	Clock does not run	RAM defective	Unit has to be switched on once again; set date and time once again; see operating instructions if necessary replace RAM

Malfunction	Fault	Reason	Remedy
Display: "Internal Pt 100 defective"	Double Pt 100 for bath temperature or safety temperature	Interruption, short circuit or temperature deviation of bath temperature probes too important	Replace double Pt 100 for bath temperature For USH 400(/6) please check both single Pt 100
Display: "Ext. Pt 100 not connected"		Tried to switch over to external control without connecting an external Pt 100	Continue to work with internal control or connect external Pt 100 for T1 or T2; look at display for control variables I, 1 or 2; check display for T1 or T2
		Tried to calibrate Pt 100 being not connected	
Display: "Correcting value too high"	Important deviation of Pt 100 from standard values	Value input differing from the basic value that is indicated by more than 5 K	Check temperature reference thermometer, check Pt 100; replace PCB "CPU"
Scale of analogue outputs shows discrepancies		Outputs not correctly calibrated	Calibrate the analogue output channels (see operating instructions)
Unit does not heat though heating is indicated	Triac		Replace triac
	Heater	Defective	Replace heater
		Interruption	Eliminate
		Electronics	Replace PCB "MP Mains"
		Controller output limitation at PAR level too small	Enter higher values at PAR level (e.g. 100 %)
Pump does not run	Temperature safety cut-out in pump has actuated Pump stops	Motor blocked	Turn propeller of motor; if necessary replace it; clean pump
		Viscosity of bath liquid too high	Use other bath liquid; wait until motor has cooled down
Bath temperature rises clearly above adjusted setpoint (Ts) Heating indication ON Heating indication OFF		Controller	Replace PCB "MP Mains" or PCB "CPU "
		Triac	Replace triac
Temperature rises slowly above adjusted setpoint Heating indication OFF	Cooling not sufficient	Heat emission of pump	Connect cooling water supply or other kind of cooling
Display shows wrong temperature (Ti, T1, T2)		Temperature probe	Replace double Pt 100 or external Pt 100 T1, T2
Display is dark	Temperature cut-out in transformer has actuated	Overload caused by short – circuit	Replace PCBs or control unit

Malfunction	Fault	Reason	Remedy
Unit does not work at adjusted setpoint		Wrong control parameters adjusted	Enter new values or start autoadaption
Temperature control by means of external controller not stable		Thermal contact of bath liquid and external measuring point not sufficient	Improve circulation through external consuming device or thermal contact to ext. Pt 100
Unit does not cool down		Controller output limitation at PAR level too small	Adjust higher value at PAR level (e.g. -100 %)
	Compressor defective		Replace refrigeration unit – by refrigeration engineer !!
	Leakage in refrigeration system		Clear leakage, fill in refrigerant – by refrigeration engineer !!
	Compressor does not run	Compressor without tension	
Triggering defective			Replace PCB "MP Mains "
Unit does not cool down	Compressor does not run	Pressure switch has actuated	Unscrew grid, clean condenser, blow through compressed air, improve ventilation
	Solenoid valves do not work correctly	Triggering defective	Replace PCB " MP Mains "
Compressor switches ON and OFF in regular periods; temperature constancy very bad	Condensation pressure too high	Fan defective	Replace fan motor
		Fan speed (only RK)	Check speed or speed controller
	Condenser dirty	Dust	Unscrew grid, from the back side blow compressed air or nitrogen through condenser
		Ventilation disturbed	Enlarge distance to nearby units or walls
		Ambient temperature too high	Air the room
Insufficient cooling in the lower temperature range		Bath liquid contaminated by condensate	Replace bath liquid to suit bath temperature
	Cools down to approx. 0°C only	Bath liquid not suitable (water)	Use water/ glycol mixture

An / To / A:

LAUDA Dr. R. Wobser • LAUDA Service Center • Fax: +49 (0) 9343 - 503-222

Von / From / De :

Firma / Company / Entreprise: _____

Straße / Street / Rue: _____

Ort / City / Ville: _____

Tel.: _____

Fax: _____

Betreiber / Responsible person / Personne responsable: _____

Hiermit bestätigen wir, daß nachfolgend aufgeführtes LAUDA-Gerät (Daten vom Typenschild):

We herewith confirm that the following LAUDA-equipment (see label):

Par la présente nous confirmons que l'appareil LAUDA (voir plaque signalétique):

Typ / Type / Type :	Serien-Nr. / Serial no. / No. de série:

mit folgendem Medium betrieben wurde

was used with the below mentioned media

a été utilisé avec le liquide suivant

Darüber hinaus bestätigen wir, daß das oben aufgeführte Gerät sorgfältig gereinigt wurde, die Anschlüsse verschlossen sind, und sich weder giftige, aggressive, radioaktive noch andere gefährliche Medien in dem Gerät befinden.

Additionally we confirm that the above mentioned equipment has been cleaned, that all connectors are closed and that there are no poisonous, aggressive, radioactive or other dangerous media inside the equipment.

D'autre part, nous confirmons que l'appareil mentionné ci-dessus a été nettoyé correctement, que les tubulures sont fermées et qu'il n'y a aucun produit toxique, agressif, radioactif ou autre produit nocif ou dangereux dans la cuve.

Stempel Seal / Cachet.	Datum Date / Date	Betreiber Responsible person / Personne responsable

Formblatt / Form / Formulaire: Unbedenk.doc
 Erstellt / published / établi: LSC
 Änd.-Stand / config-level / Version: 0.1
 Datum / date: 30.10.1998

LAUDA DR. R. WOBSE GmbH & Co. KG
 Pfarrstraße 41/43 Tel: +49 (0)9343 / 503-0
 D - 97922 Lauda-Königshofen Fax: +49 (0)9343 / 503-222
 Internet: <http://www.lauda.de> E-mail: info@lauda.de